

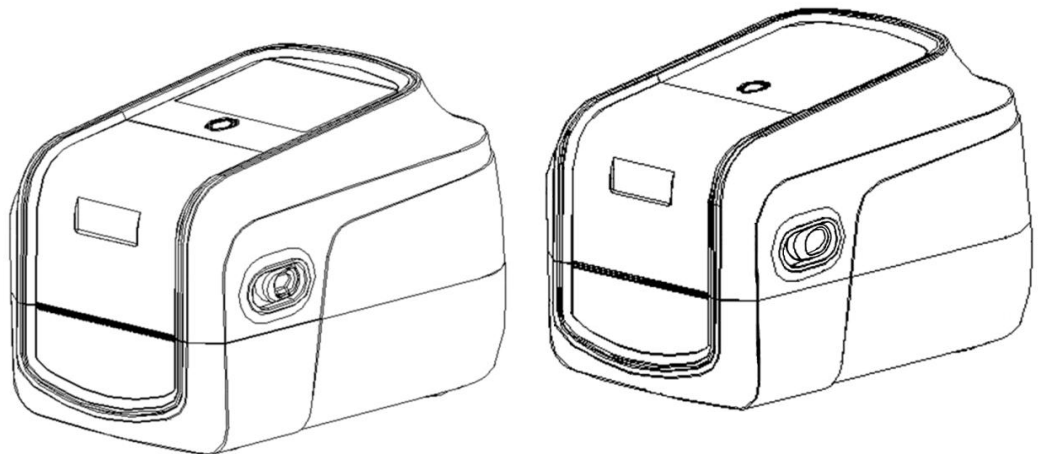

GA-2408T / GA-3406T / GA-6404T / Series

**THERMAL TRANSFER / DIRECT THERMAL
APEX LABEL PRINTER**

**USER'S
MANUAL**



Ver.1.1.0

Agency Compliance and Approvals

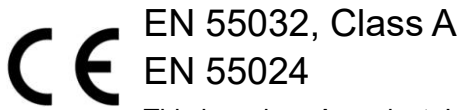

This is a class A product. In a domestic environment this product may cause radio interference in which case the user may be required to take adequate measures.

FCC part 15B, Class A



This equipment has been tested and found to comply with the limits for a Class A digital device, pursuant to Part 15 of the FCC Rules. These limits are designed to provide reasonable protection against harmful interference when the equipment is operated in a commercial environment. This equipment generates, uses, and can radiate radio frequency energy and, if not installed and used in accordance with the manufacturer's instruction manual, may cause harmful interference with radio communications. Operation of this equipment in a residential area is likely to cause harmful interference, in which case you will be required to correct the interference at your own expense.

WARNING

This is a Class A product. In a domestic environment this product may cause radio interference in which case the user may be required to take adequate measures.

FCC radiation exposure statement

(Suitable for printer with RFID encoder)

This device complies with FCC radiation exposure limits set for uncontrolled environments. The device should be installed and operated with a minimum distance of at least 200mm between the radiation source and the user.

This transmitter shall not be in the same position or work in conjunction with any other antenna or transmitter .

Environmental protection



Do not dispose of this product in an unsorted public trash can. You should recycle this product according to local regulations.

For more information, please browse our website : <http://www.gainscha.com.tw>

Contents

- 1. Introduction 7
 - 1.1 Product Introduction 7
 - 1.2 Product Features 9
 - 1.2.1 Printer Standard Features 9
- 2. Operations Overview 13
 - 2.1 Unpacking and Inspection 13
 - 2.2 Printer Overview 14
 - 2.2.1 Front View 14
 - 2.2.2 Interior View all Series (Contains Eco-friendly printing solutions introduction) 19
 - 2.2.3 Front View (All Series) 21
 - 2.2.4 Rear View (All Series) 21
 - 2.2.5 The Antenna Part 22
- 3. Setup 23
 - 3.1 Setting up the Printer 23
 - 3.2 Install Printer Driver (All Series) 24
 - 3.3 Loading the Ribbon 27
 - 3.4 Loading the Media 28

3.4.1 Loading the Roll Labels	28
3.4.2 Ribbon and print media loading diagram	28
3.5 Loading the Cutter	29
3.6 Loading the Peeler	32
4. Button Functions	35
4.1 Regular Button Functions	35
4.2 Power-on Utilities	35
5. Printer Utility	37
5.1 Start the Printer Utility	37
5.2 Printer Utility(obtain printer status & information)	38
5.3 Printer Setup	38
5.4 System Setup	41
5.5 Gap Sensor Setup	42
5.6 RFID Module Setup	43
5.7 RFID Setup	43
5.8 Wi-Fi Setup	45
5.9 Bluetooth Setup	46
5.10 RS232 Setup	47
5.11 Ethernet Setup	47

5.12	Setting File	48
5.13	Printer Utility - Command Tool	49
	1. Send Command	49
	2. Send File	49
5.14	Printer Utility – Printer Function	50
5.15	Printer Utility – File Manager	51
	1. File Lists	51
	2. Add File	51
5.16	Printer Utility – Port Settings	52
	1. USB port	52
	2. RS232	52
	3. Ethernet	53
	4. Wi-Fi	53
5.17	Printer Utility – RFID Test	53
	1. Write Data	53
	2. Read Data	54
	3. Access Password Setup	55
	4. RFID-Read Access Password	56
	5. RFID-Kill Password Setup	56

6. Read Kill Password	57
7. Remove Tag	57
6. Label editing software - BarTender	58
1. Design labels and print contents on labels	58
2. Import the database	59
3. Call database batch printing	61
4. Batch serialized print	63
5. Add RFID Tags in BarTender	64
6. RFID option in BarTender	65
7. The Use of RFID Function	67
1. ISO 18000-6C protocol introduction	67
1) Abstract	67
2) Data Storage Area	67
2. RFID Driver Installation	68
3. RFID Calibration	69
1) Auto Calibration	69
2) Manual Calibration	70
3) Calibration Failure	70
3.1 Set Access Password	71

3.2 Set Kill Password	71
8. RFID data is written in BarTender	72
8.1 Writes Open Data in EPC Area	72
8.2 Rules for writing data in LOCK state	73
8.3 EPC Area Writes Locking Data	73
8.4 Data read rule in LOCK state	73
9. Other RFID Function Setting	74
10. Printer Program Upgrade	75
1. Printer status upgrade	75
2. Debug mode upgrade program	76
11. LCD Menu Function for GA-2408T , GA- 3406T, GA-6404T Series	79
11.1 Enter the Menu	79
11.2 Menu Overview	80
11.3 Error and screen message introduction	83
12. Communication interfaces	86
1) USB (A Type)	86
2) USB (B Type)	86
3) Serial Port	87
4) Ethernet Port	87

13. Troubleshooting 88

 13.1 Common Problems 88

14. Maintenance 90

15. Revise History 91

1. Introduction

1.1 Product Introduction

Thank you very much for purchasing Gainscha bar code label printer.

The T series printer features the single motor that is capable of handling a large capacity of 300 meters ribbon and large rolls of media inside its sleek design. If the 5" interior label capacity is not enough, simply add an external media roll mount and the GS series can easily handle 8" OD rolls of labels designed for expensive industrial label printers.

To meet the various printing requirements, T series provides different memory capacity. Moreover, T series have optional peel-off and cutter kits for users to purchase. The movable black mark sensor design can accept a wide range of label media. All of the most frequently used bar code formats are included. Fonts and bar codes can be printed in any one of the four directions.

The T series printer is built-in the flexible firmware design, user can download various printer commands to perform the work. Please refer to the types of printer commands supported in the specifications. By integrating rich features, it is the most cost-effective and high-performance printer in its class!

To print label formats, please refer to the instructions provided with your labeling software, available on Gainscha website <http://www.gainscha.com.tw>

- Applications

- o Manufacturing & Warehousing

- Work in Progress
 - Item Labels
 - Instruction labels
 - Agency labels
 - Compliance labels
 - Logistics management labels
 - Electronics labels

- o Parcel Post

- Shipping/ Receiving Labels

- o Healthcare

- Patient Identification
 - Pharmacy
 - Specimen Identification

- o Retail Marking

- Price tags
 - Shelf labels
 - Jewelry tags
 - Asset management labels
 - Care labels

- o Small Office/ Home Office

1.2 Product Features

1.2.1 Printer Standard Features

PRINTER MODEL	GA-2408T	GA-3406T	GA-2408T	GA-3406T	GA-6404T
Grade	Standard	Standard	Empower	Empower	Empower
Resolution	8dots/mm (203DPI)	12dots/mm (300DPI)	8dots/mm (203DPI)	12dots/mm (300DPI)	23.6dots/mm (600DPI)
Printing Method	Thermal Transfer & Direct Thermal				
Max. print speed	203mm(8")/ second	152mm(6")/ second	203mm(8")/ second	152mm(6")/ second	101.6mm(4")/ second
Max. print width	104 mm (4.1")	108.4 mm (4.27")	104 mm (4.1")	108.4 mm (4.27")	105.6 mm (4.16")
Max. print length	25,400mm (1,000")	11,430mm (450")	25,400mm (1,000")	11,430mm (450")	25,400mm (1,000")
Enclosure	Clamshell with double-walled plastic				
CPU	400 MHZ, 32 bits, ARM9				400 MHZ, 32 bits, ARM9
Memory RAM	128 MB SDRAM				128 MB SDRAM
Memory ROM	128 MB Flash Memory				128 MB Flash Memory
Interface	<ul style="list-style-type: none"> • USB 2.0 High Speed 480Mbps • USB Host 2.0, for scanner or PC keyboard • Internal Ethernet 10/100Mbps • RS-232 • Internal Bluetooth 4.0 (factory option) • Internal WiFi (factory option) 				
Real Time Clock	Standard				
Buzzer	Standard				
Dealer options	<ul style="list-style-type: none"> • Guillotine cutter (full cut and partial cut) • Guillotine cutter for Linerless thermal label 				

	<ul style="list-style-type: none"> • Peeler 		
Sensors	<ul style="list-style-type: none"> • Head open sensor, Ribbon end sensor, Reflective sensor (moveable), Transmissive sensor (moveable) • Guillotine cutting system with a peel-off sensor 		
Power	<p>External universal switching power supply</p> <p>Input: AC 100-240V, 2.5A, 50-60Hz, Output: DC 24V, 2.5A, 60W</p>		
User Interface	<table border="0"> <tr> <td> <ul style="list-style-type: none"> • 1 power switch • 1 button (Feed) • 5 LEDs (Online blue, Error red, Ribbon green, Communication orange, Press-key white) </td> <td> <ul style="list-style-type: none"> • 1 power switch • 1 button (Feed) • 1 LEDs (Press-key white) • 4.3" TFT-LCD 480x272 dots with Capacitive touch panel </td> </tr> </table>	<ul style="list-style-type: none"> • 1 power switch • 1 button (Feed) • 5 LEDs (Online blue, Error red, Ribbon green, Communication orange, Press-key white) 	<ul style="list-style-type: none"> • 1 power switch • 1 button (Feed) • 1 LEDs (Press-key white) • 4.3" TFT-LCD 480x272 dots with Capacitive touch panel
<ul style="list-style-type: none"> • 1 power switch • 1 button (Feed) • 5 LEDs (Online blue, Error red, Ribbon green, Communication orange, Press-key white) 	<ul style="list-style-type: none"> • 1 power switch • 1 button (Feed) • 1 LEDs (Press-key white) • 4.3" TFT-LCD 480x272 dots with Capacitive touch panel 		
Internal fonts	<table border="0"> <tr> <td> <ul style="list-style-type: none"> • 8 alpha-numeric bitmap fonts • True type font engine (need download scalable font file) </td> <td> <ul style="list-style-type: none"> • 8 alpha-numeric bitmap fonts • True type font engine (need download scalable font file) • GB18030 Simplified Chinese 24x24, 16x16 • BIG5 Tradition Chinese 24x24, 16x16 </td> </tr> </table>	<ul style="list-style-type: none"> • 8 alpha-numeric bitmap fonts • True type font engine (need download scalable font file) 	<ul style="list-style-type: none"> • 8 alpha-numeric bitmap fonts • True type font engine (need download scalable font file) • GB18030 Simplified Chinese 24x24, 16x16 • BIG5 Tradition Chinese 24x24, 16x16
<ul style="list-style-type: none"> • 8 alpha-numeric bitmap fonts • True type font engine (need download scalable font file) 	<ul style="list-style-type: none"> • 8 alpha-numeric bitmap fonts • True type font engine (need download scalable font file) • GB18030 Simplified Chinese 24x24, 16x16 • BIG5 Tradition Chinese 24x24, 16x16 		
1D Barcode	Code 11, Code 39, Code 93, Code 128 (subsets A, B, C), UPC-A, UPC-E, UCC-128, Codabar, EAN/JAN-8, EAN/JAN-13, Interleaved 2 of 5, ITF14, MSI Pleassy, PostCode, Telepen		
2D Barcode	QR Code, Micro QR Code, PDF417, Micro PDF417, MaxiCode, Aztec Code, Data Matrix		
Rotation	Font and barcode support 0, 90, 180, 270 degree		
Printer language	Compatible to TSPL, EPL, ZPL, ZPL II, DPL		
Ribbon	300 M long, max. OD 67 mm, 1" core (ink coated outside)		
Ribbon width	30 mm ~ 110 mm (1.18" ~ 4.3")		
Media type	Continuous, die-cut, black mark, fan-fold (outside wound), Linerless Thermal Label, On-metal tag support		
Media width	20~ 118 mm (0.7" ~ 4.6")		

Media thickness	0.06~0.254mm (2.36 ~ 10 mil)				
Media core diameter	25.4 mm (1")				
Label roll capacity	127 mm (5") OD				
Label length	5 ~25,400 mm (0.2" ~ 1,000")	5 ~11,430 mm (0.2" ~450")	5 ~25,400 mm (0.2" ~ 1000")	5 ~11,430 mm (0.2" ~450")	5 ~11,430 mm (0.2" ~450")
Physical dimension	280mm(L)*190mm(W)*198.3mm(H)				
Safety regulation	FCC Class A, CE Class A, CCC, BIS, CB				
Environment condition	Operation: 5 ~ 40°C, 25 ~ 85% non-condensing Storage: -40 ~ 60°C, 10 ~ 90% non-condensing				
Environmental concern	Comply with RoHS, REACH, WEEE				
Accessories	<ul style="list-style-type: none"> • Windows labeling software CD disk • Quick start guide • USB cable • Power cord • 1" ribbon spindle x 2 for 300M ribbon • External universal switching power supply 				

1.2.2 Printer Optional Features

Product option feature	User options	Dealer options	Factory options
Peeler module		<input type="radio"/>	<input type="radio"/>
Regular full cut cutter (Guillotine cutter) Media thickness: 0.06~0.19 mm Media type: receipt and label liner w/o glue		<input type="radio"/>	<input type="radio"/>
Regular full/partial cutter (TextileCare Cutter)		<input type="radio"/>	<input type="radio"/>
linerless cutter		<input type="radio"/>	<input type="radio"/>
Internal Bluetooth module		<input type="radio"/>	<input type="radio"/>
Internal WIFI module		<input type="radio"/>	<input type="radio"/>
Internal Bluetooth and WIFI module		<input type="radio"/>	<input type="radio"/>

NOTE : Except for the linerless cutter, all regular/heavy duty/care label cutters DO NOT cut on media with glue.

2. Operations Overview

2.1 Unpacking and Inspection

This printer has been specially packaged to withstand damage during shipping. Please carefully inspect the packaging and printer upon receiving the bar code printer. Please retain the packaging materials in case you need to reship the printer.

Unpacking the printer, the following items are included in the carton.

- One printer unit
- One quick installation guide
- One power cord
- One external universal switching power supply
- One USB interface cable
- 1inch core ribbon shaft for 300m ribbon
- One sample ribbon and Label roll
- One Windows labeling software/Windows driver CD disk

If any parts are missing, please contact the Customer Service Department of your purchased reseller or distributor.

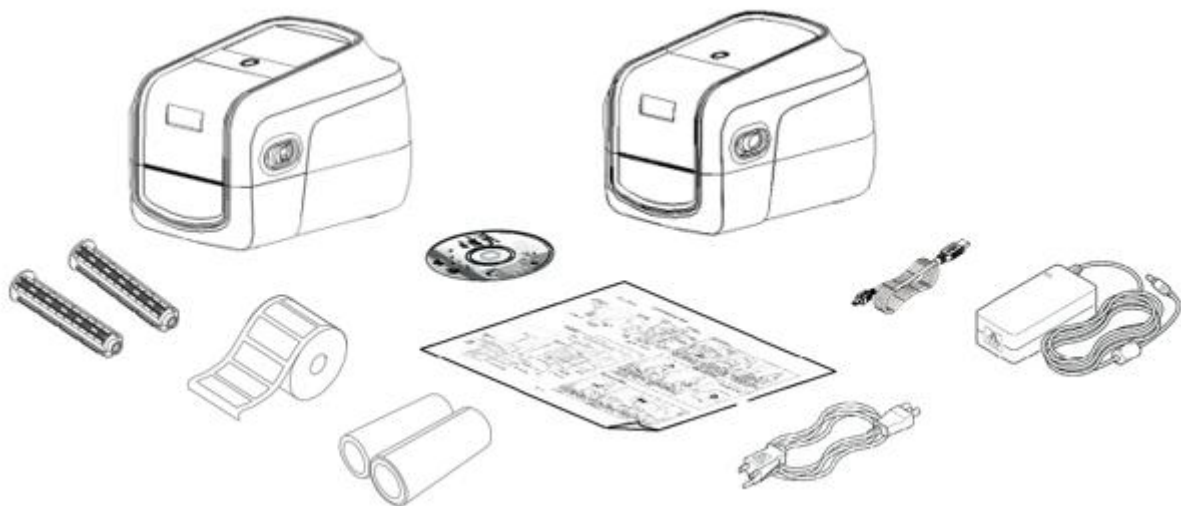

2.2 Printer Overview

2.2.1 Front View

GA-2408T、GA-3406T Series(Contains LED indicator’s function introduction)

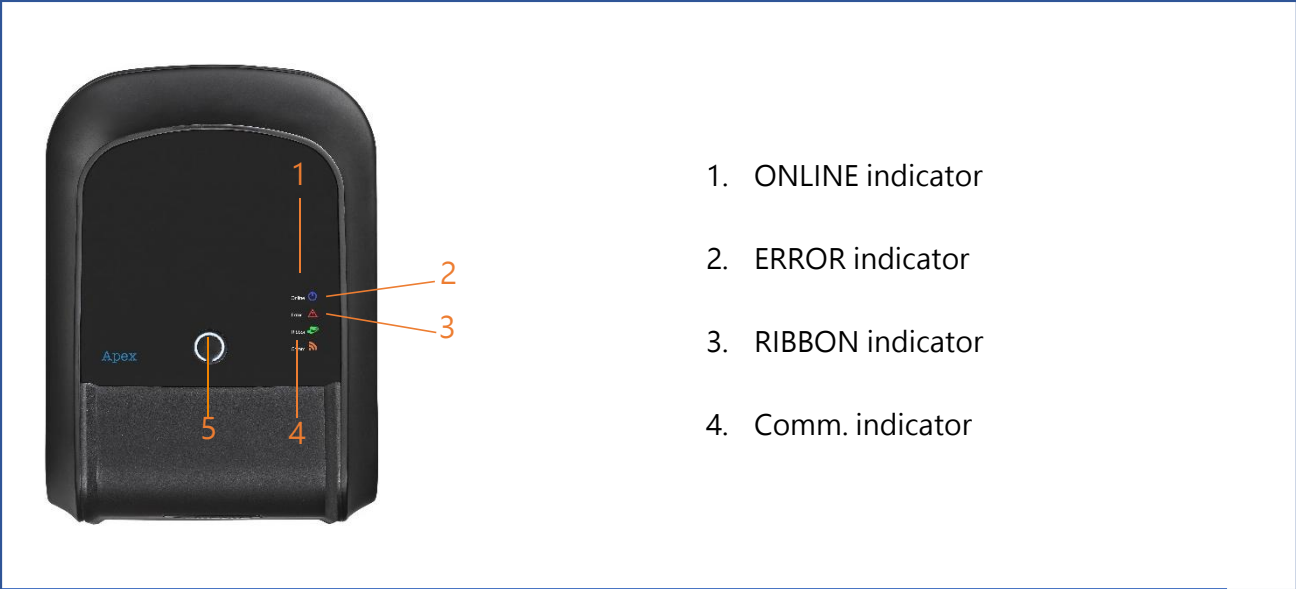

- 1. ONLINE indicator
- 2. ERROR indicator
- 3. RIBBON indicator
- 4. Comm. indicator

Operation buttons	
Buttons	Function
FEED / PAUSE / ERROR CANCEL button 	In the ready state, press this button, the printer will spit a sheet of paper, in the printing state, press this button, the printer will stop immediately, in the error state, press this button, the printer will cancel the error state and restore printing function.

LED Indicator



Event	Description
Thermal transfer mode ready	Blue(ONLINE) and Green(RIBBON) solid, and the device is ready to use.
Direct thermal mode ready	Blue(ONLINE) solid, and the device is ready to use.
Open cover	When the cover is open, a beep sound will be made, and Blue(ONLINE), Red (ERROR), and Green(RIBBON) will flash.
PAUSE	Press the PAUSE button. When the Blue(ONLINE) flash, the printer will pause.
FEED	Press the FEED button to print as per demand, Blue(ONLINE) will flash.
Out of paper	When out of paper, a beep sound will be made, and Red(ERROR) flash
Out of ribbon	When out of ribbon, a beep sound will be made, and Red(ERROR) solid · Green(RIBBON) flash
Label gap/black mark error	When label gap/black can't be found, a beep sound will be made, and Red(ERROR) Blue(ONLINE) flash
Cutter error	When cutter can't be found, a beep sound will be made, and Blue(ONLINE) · Red(ERROR) Both flash alternately, flash with Green(RIBBON)
Print head overheated	When print head overheated ,a beep sound will be made, and Blue(ONLINE)and Red(ERROP) alternately flash

Other errors	When other errors ,a beep sound will be made, and Red(ERROP) and Green(RIBBON) alternately flash
Ethernet ready	When the RJ45 network cable is plugged in and the connection is normal, the Orange(COMM) flash
WIFI ready	When the WIFI's AP or STA mode is connected, the orange(COMM) solid
Ethernet +WIFI ready	When the RJ45 network cable is plugged in, and the connection is normal, and the WIFI's AP or STA mode is connected, the orange (COMM) will be solid for 2 seconds and the orange(COMM) flash.

GA-2408T、GA-3406T、GA-6404T Series (Contains LCD monitor operation

introduction)

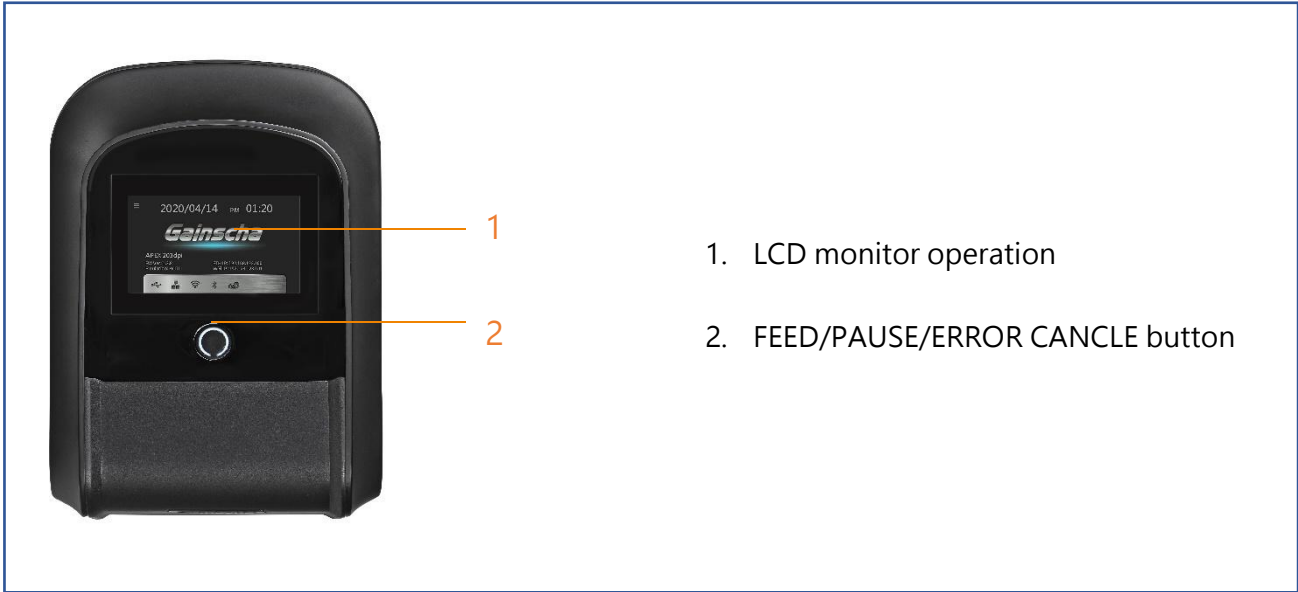







- 1. LCD monitor operation
- 2. FEED/PAUSE/ERROR CANCEL button

FE Ver: printer
firmware
version
Emulation: Simulation
instruction category



- time/da
- Printer
- Printer



Operation buttons	
Buttons	Function
FEED / PAUSE / ERROR CANCEL button 	In the ready state, press this button, the printer will spit a sheet of paper, in the printing state, press this button, the printer will stop immediately, in the error state, press this button, the printer will cancel the error state and restore printing function.
Main page icons	
Indicated icon	Indication
	Ethernet is connected
	Wi-Fi device is ready
	Bluetooth device is ready
	USB HID is connected · ex: USB scanner · USB keyboard
	Thermal transfer mode · use ribbon function

2.2.2 Interior View all Series (Contains Eco-friendly printing solutions introduction)

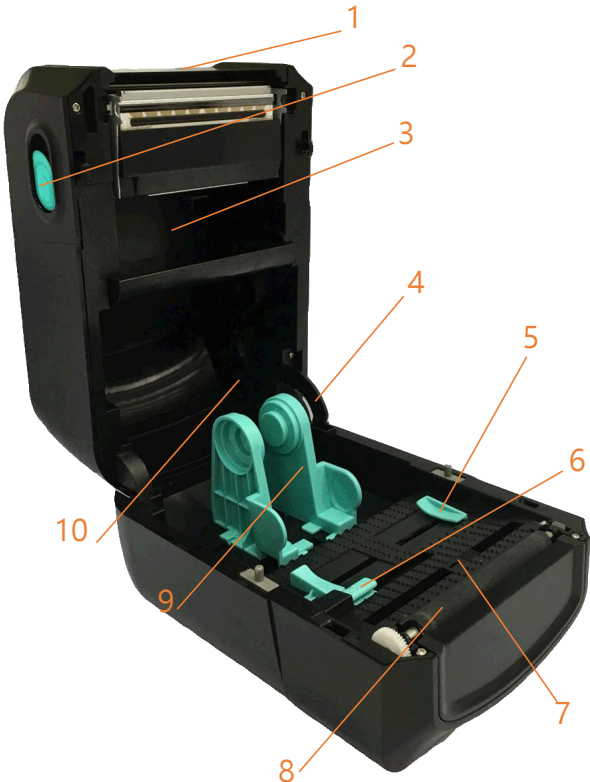

- 1. Printer top cover
- 2. Top cover open tab
- 3. The place for new ribbon
- 4. top cover support
- 5. Media guide
- 6. Gap sensor
- 7. Black mark sensor
- 8. Platen roller
- 9. Media holder locker
- 10. Fixing tabs

Eco-friendly printing solutions

Introduction

Used for printing on linerless label, which saves consumables and improves the environment.

application

Linerless Label vs Standard Label



Linerless Label

VS



Standard Label

Benefits of using linerless labels

- More labels per roll-increase of 30-40%
- No liner waste removes the risk of injury through slippage
- Less waste disposal translates to less carbon emission
- Reduced transportation costs
- Supports a lower carbon footprint
- Less storage space required

2.2.3 Front View (All Series)

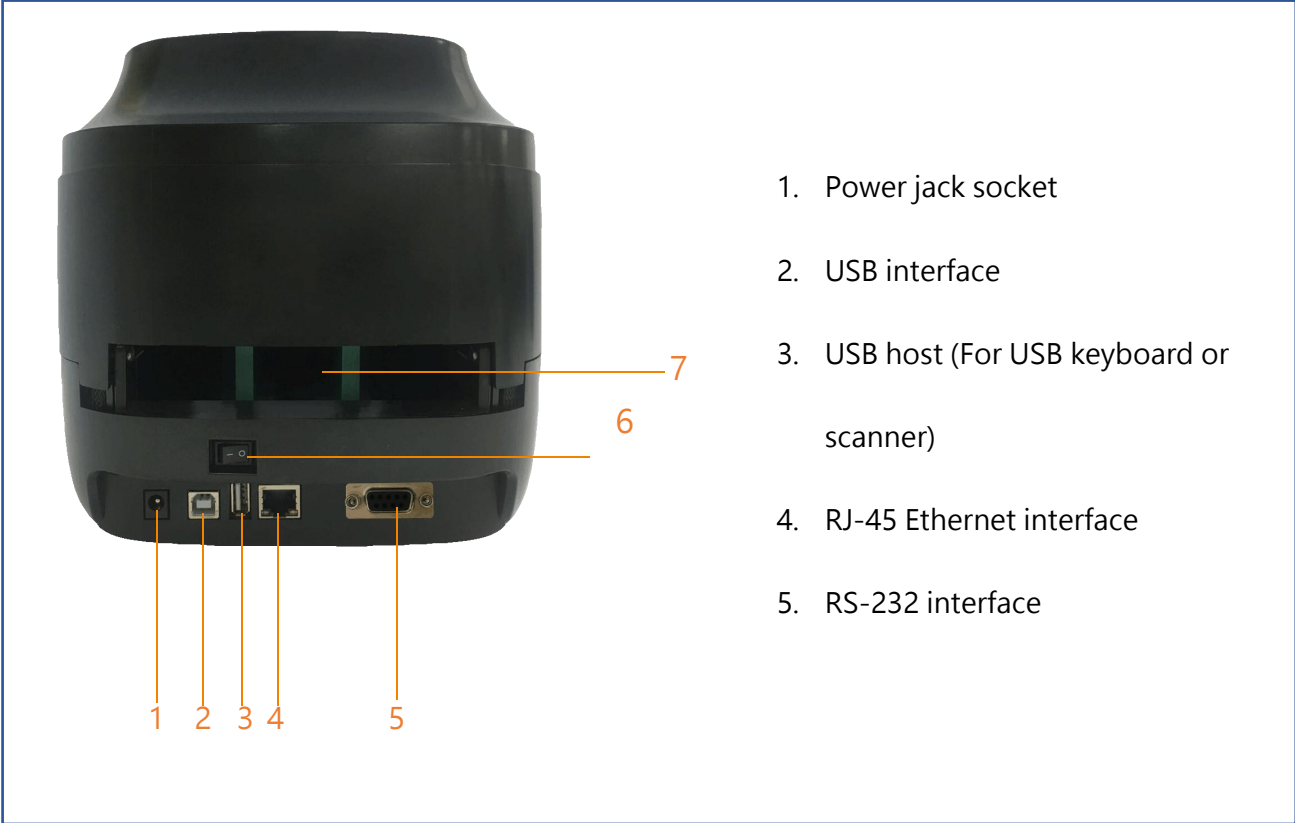

2.2.5 The Antenna Part



Yellow Light

Power indicator: When the RFID module is connected to the power supply, the yellow light is long on, if not, it means that the RFID module is not energized.

Blue Light

Operation indicator: When the printer performs RFID command operation, the blue light flashes once(The blue light flashed once in each RFID command operation.)

3. Setup

3.1 Setting up the Printer

Place the printer on a flat, secure surface, then follow the steps below:

1. Plug the power cord into the AC power cord socket at the rear of the printer. Then, plug the other side into a properly grounded power outlet.
2. Connect the printer to the computer with the provided USB cable.
3. Push the power switch on "-" side to open the power of printer.

NOTE:

- * Please switch OFF printer power prior to plugging in the power cord to printer power jack.
- * The interface picture here is for reference only. Please refer to the product specification for the interfaces availability.

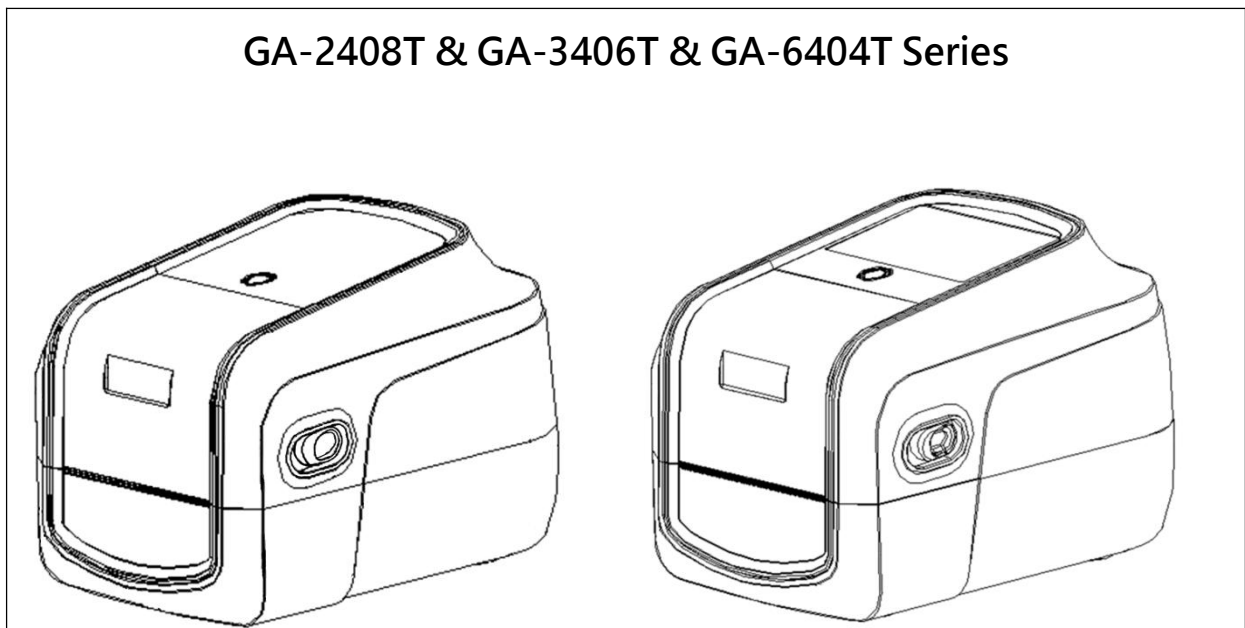

3.2 Install Printer Driver (All Series)



(GA-2408T/GA-3406T/GA-6404T)



1. Read the license agreement, click [I accept the terms in license agreement], and click [Next].

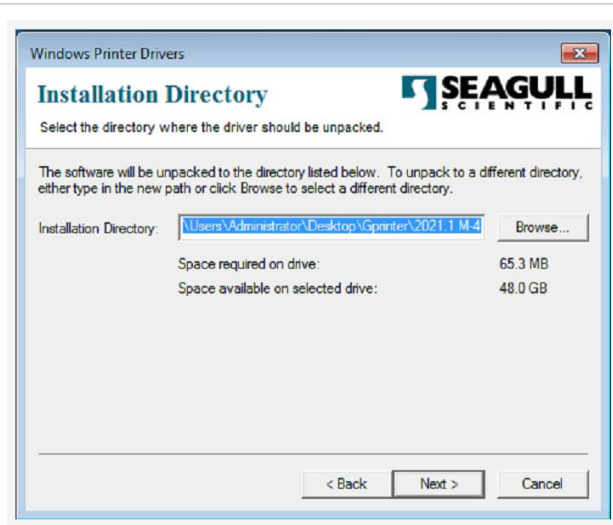

2. Select a installation directory and click [Next].

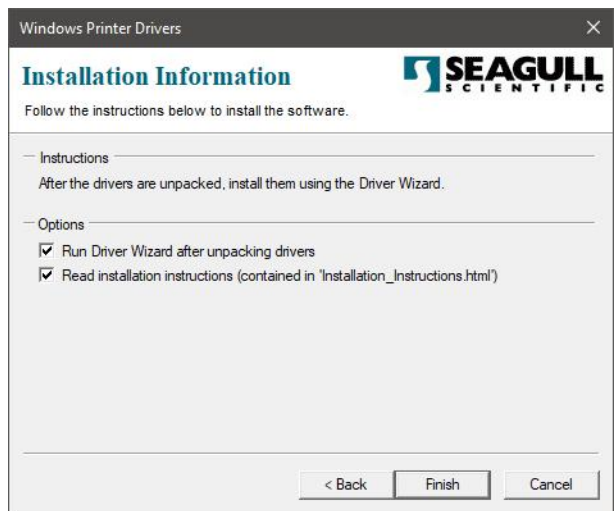

3. Click [Finish].



4. Go to installation process, please click [Install Printer Driver], and then click [Next].

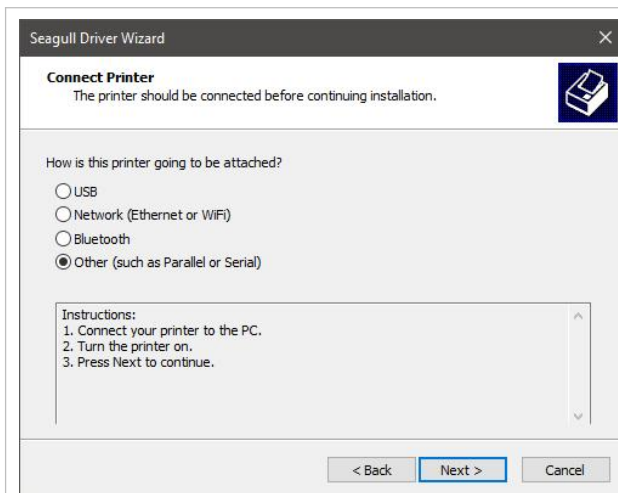

5. Click [Other] and click [Next].

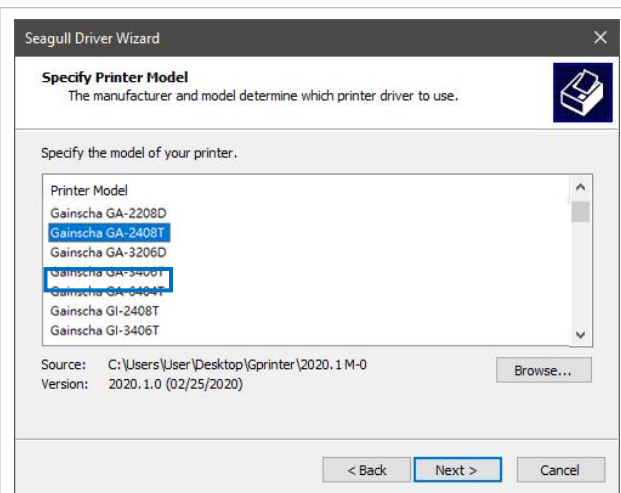

6. Select printer model name, click to install and click [Next].

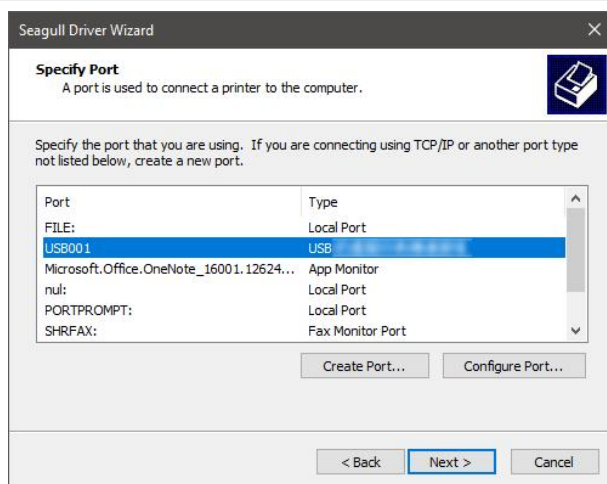

7. Please use a USB cable to connect the printer to the computer, click the corresponding USB interface, and click [Next].

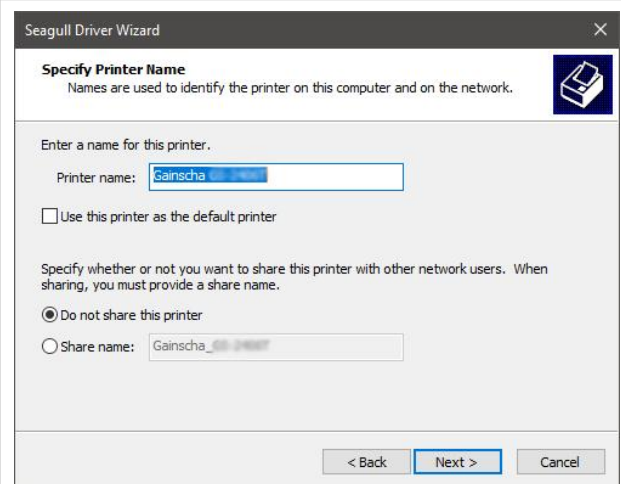

8. Change the printer name as per need, and click [Next].

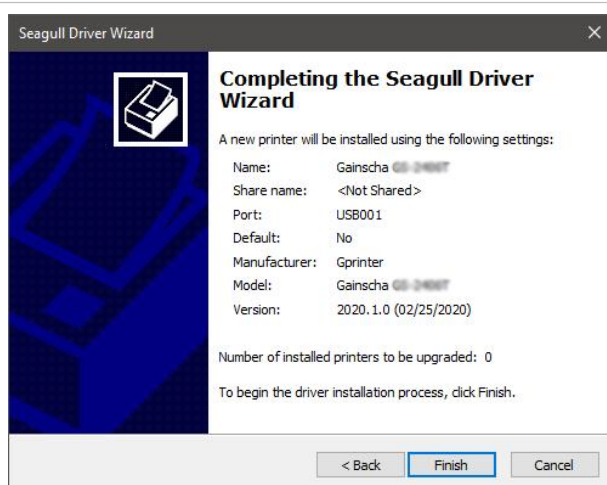

9. Click [Finish].

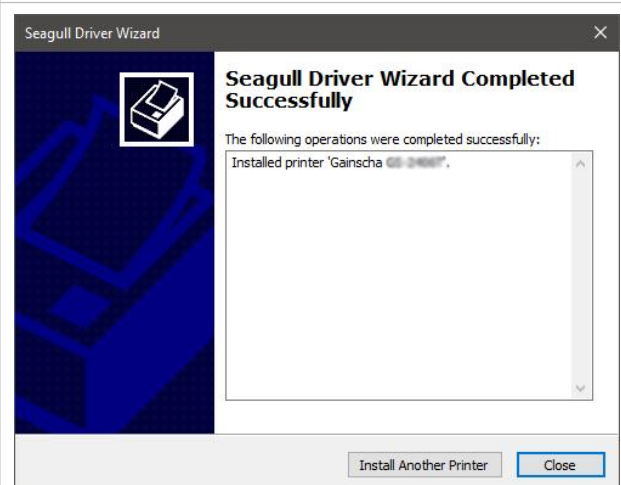

10. The installation is completed, please

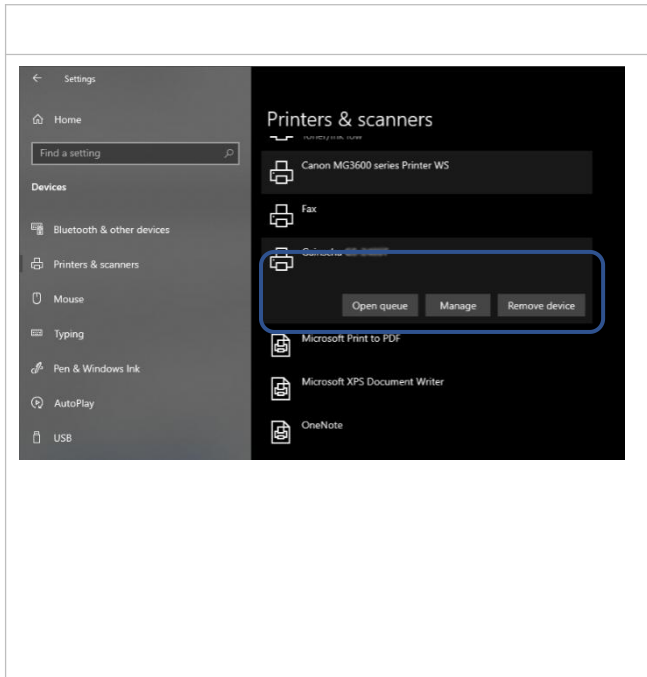

click [Close].

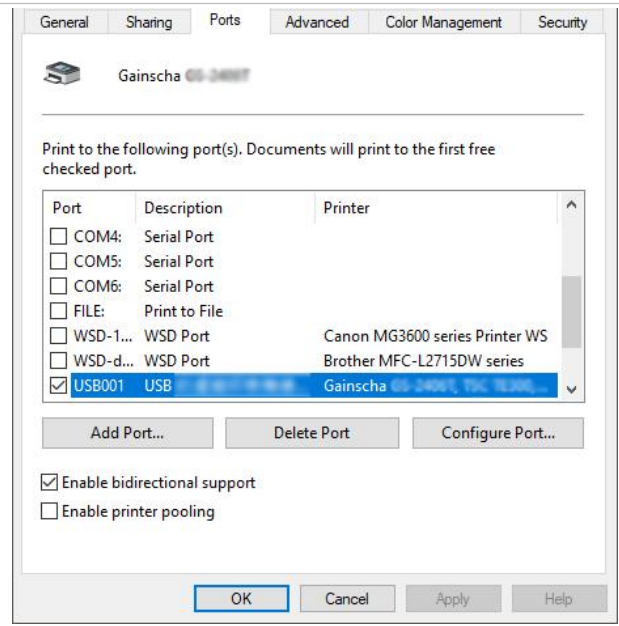

11. Users can check whether the installation is completed through the following ways:
- If Windows 10, check from [Windows Settings] → [Devices] → [Printers and Scanners].
 - Check from [Control Panel] → [Devices and Printers].

12. Users can change printer interface through the following ways:
- In Windows 10, [Windows Settings] → [Printers and Scanners] → [Devices] → select the corresponding printer model → [Management] → [Printer Content] → [Port] to change different USB port / COM port as per need.
 - From [Control Panel] → [Devices and Printers] → select the corresponding printer model → right-click → [Printer Content] → [Port] to modify it.

3.3 Loading the Ribbon

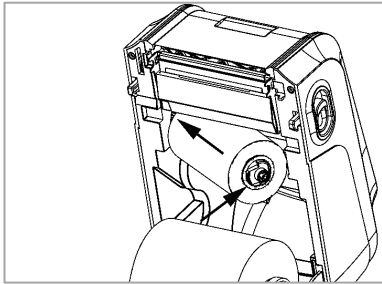
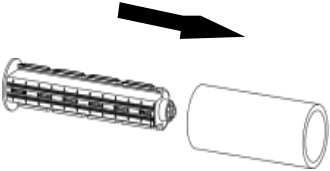
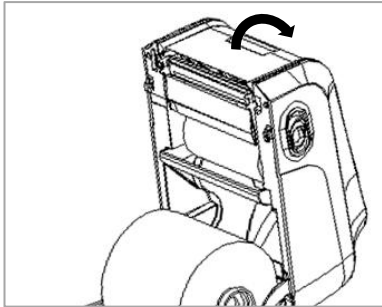
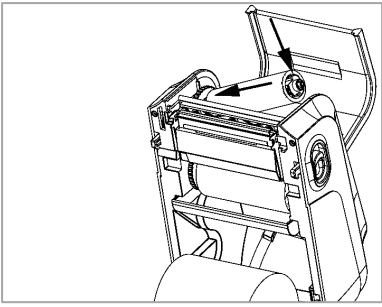
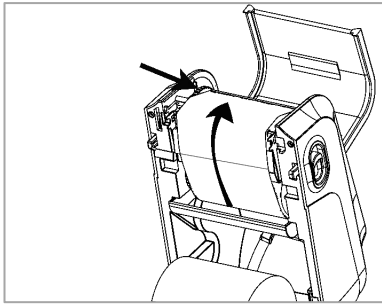
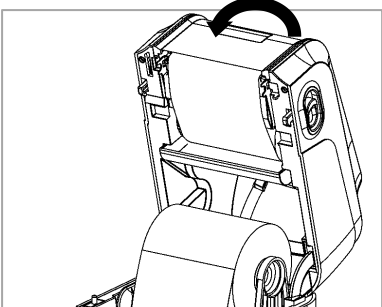
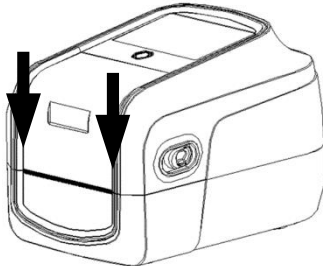
	
<p>1. Insert black ribbon roller into new ribbon.</p>	<p>2. Load ribbon left side first and then right side, fix it well.</p>
	
<p>3. Insert blue ribbon roller into the empty roll for ribbon collecting after printed.</p>	<p>4. Open the front cover.</p>
	
<p>5. Load the empty roll left side first, then right side.</p>	<p>6. Pull out ribbon and stick into the empty roll. Make sure ribbon is flat and smooth when touch print head.</p>
	
<p>7. Close the front cover.</p>	<p>8. Carefully close top cover.</p>

3.4 Loading the Media

3.4.1 Loading the Roll Labels

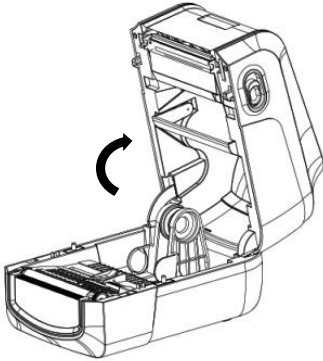
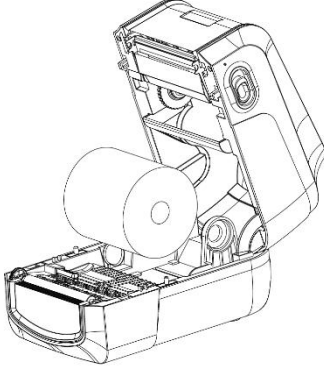
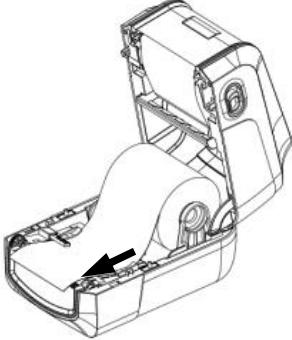
	
<p>1. Press two buttons on printer two sides to lift and open the cover.</p>	<p>2. Load print media into the printer; adjust the paper guide to be same width of print media.</p>
	
<p>3. Pull out the print media till it pass gap sensor and cutter (cutter is optional), complete media loading.</p>	

3.4.2 Ribbon and print media loading diagram

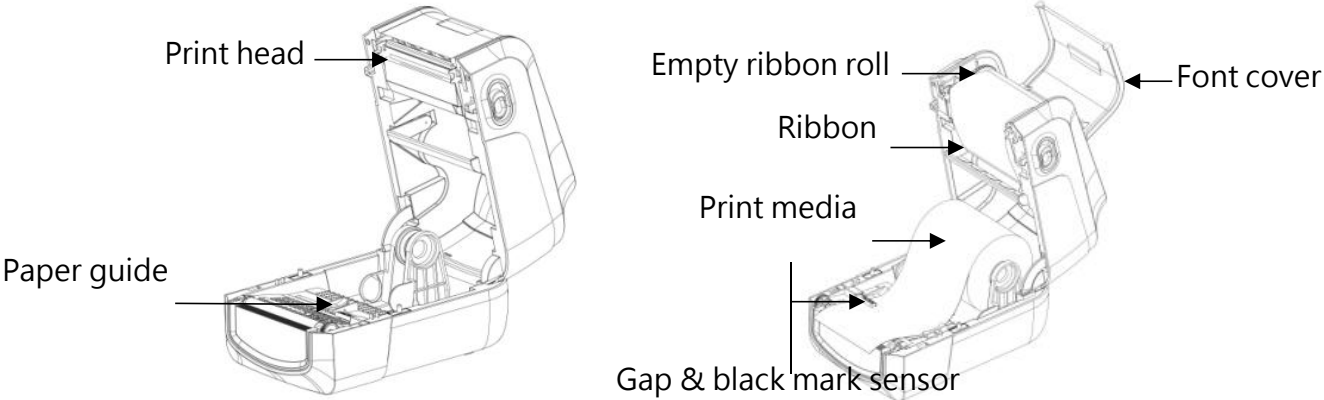



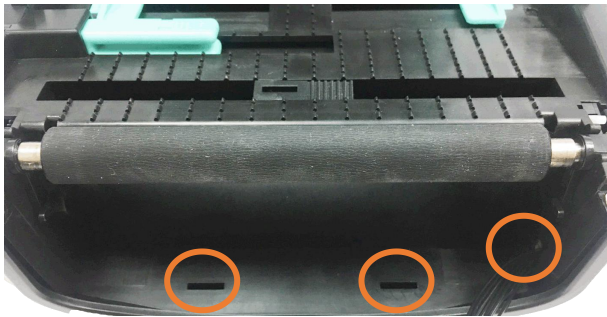

3.5 Loading the Cutter

	<p>Depending on the purchase, there will be two different cutters.</p> <ol style="list-style-type: none">1. Textile Care Cutter2. Guillotine cutter
	<ol style="list-style-type: none">1. Push the cover button backwards with both hands to open the printer cover.
	<ol style="list-style-type: none">2. Remove the two screws located on the front bezel, and push it out.

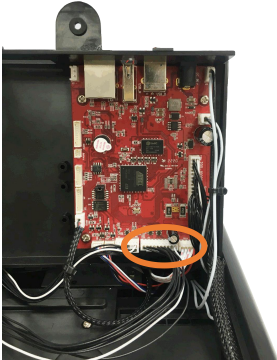

3. Align the cutter with the tenon, and place the wire of the cutter into the hole
4. When attaching the cutter, take care not to press it on the wire, lock the cutter with the screw, and cover the upper cover.

	<p>5. After closing the upper cover, turn the printer upside down, remove a screw located on the bottom cover, and open the bottom cover.</p>
	<p>6. After opening, pull out the wire just put into the hole and insert it into the wafer 1x10P on the main board.</p>
	<p>7. After inserting it, cover the bottom cover and lock the screw.</p>
	<p>8. Finish.</p>

3.6 Loading the Peeler

	<p>Peeler.</p>
	<p>1. Push the cover button backwards with both hands to open the printer cover.</p>
	<p>2. Remove the two screws located on the front bezel, and push it out.</p>

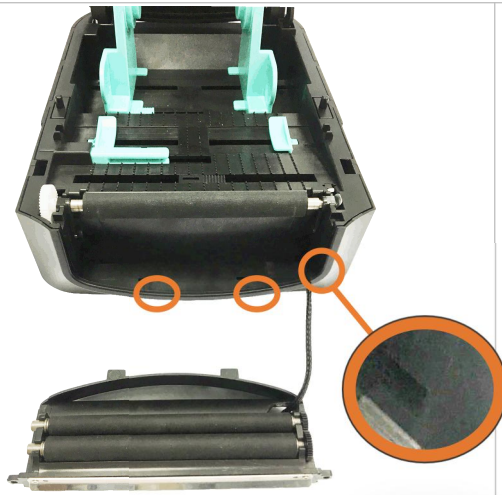

3. Align the peeler with the tenon and place the wire of the peeler into the hole.

4. When closing the peeler, be careful not to press it on the wire, and lock the peeler with screws.



5. Turn the printer upside down, remove a screw located on the bottom cover, and open the bottom cover.

	<p>6. After opening, pull out the wire just put into the hole and insert it into the wafer 1x10P on the main board.</p>
	<p>7. After inserting it, cover the bottom cover and lock the screw.</p>
	<p>8. Finish.</p>

Note: Please clamp the label roll with the fixing tabs and clamp the media with the media guide, so as not to cause the media to roll into the peeler and cause the phenomenon that the media cannot be peeled off.

4. Button Functions

4.1 Regular Button Functions

This printer has one button for feed, pause or cancel errors. There are different functions in different modes, as shown in the following table:



Button	Printer status	Function	Description
Feed button	Ready	Feed	When the printer is ready (Blue LED ON), press this button once, and the label will advance to the front of the next label
Feed button	Wait for push button to print	Print next	When the button Demand function is activated, the printer will stop after printing and wait for the user to press this button before printing the next label.
Feed button	Print mode	Pause	When the printer is printing continuously, pressing the (PAUSE) button will pause printing. The power indicator is blue flashing. Just press the button again, and the print job returns to normal.
Feed button	Error occurred	Cancel error	When the error RED is on, press the (PAUSE) button once, the printer will cancel the error and resume printing function, and reprint the label layout when the error occurs.









4.2 Power-on Utilities

This printer has six power-on functions for setting or testing the printer's hardware.

Press these buttons at the same time when the power is turned on, and release the buttons with the light signal to activate these functions.

Follow these steps to enable the boot function:

Event	Description	Status lights	Beep
Self-test	A. Power off the printer B. Make sure the printer is loaded with paper and close the printer cover		

	<p>C. Press and hold the FEED button, and turn on the printer power. When the ribbon Green solid alone, release the button. At this time, the printer will print a self-test page after turning on the printer.</p>		
<p>Enter USB storage device function</p>	<p>A. Power off the printer</p> <p>B. Make sure the printer is loaded with paper and close the printer cover</p> <p>C. Press and hold the FEED button and turn on the printer power. When the comm. Orange solid alone, release the button. At this time, the printer's storage device will appear on the computer.</p>		
<p>Enter dump mode</p>	<p>A. Power off the printer</p> <p>B. Make sure the printer is loaded with paper and close the printer cover</p> <p>C. Press and hold the FEED button, then turn on the printer. When the online Blue and the error Red are on at the same time, release the FEED button, and the printer is now turning on After the printer, a beep is heard, and the printer enters the dump mode at this time, and it will print out "NOW IN DUMP MODE"</p>		
<p>Skip AUTO.BAS</p>	<p>A. Power off the printer</p> <p>B. Press and hold the FEED button and turn on the printer's power. When the error Red solid alone, release the button. At this time, the printer will hear two beeps after turning on the printer, and the printer will skip AUTO.BAS program</p>		
<p>Printer initialization</p>	<p>A. Power off the printer</p> <p>B. Press and hold the FEED button and turn on the printer power. When the online Blue solid alone, release the button. At this time, the printer will hear five beeps after turning on the printer, and the printer will print the meter parameters are restored to the factory default settings</p>		
<p>Ribbon inspection</p>	<p>The machine will automatically detect the status of the ribbon after turning on and in each thermal transfer printing mode.</p>		

5. Printer Utility

Printer Utility is an integrated tool software that helps users query printer settings and status, change printer-related settings, and send commands or files to the printer.

5.1 Start the Printer Utility

1. Please mouse over Printer Utility icon  Printer Utility.exe image Double click left mouse button.
2. After opening the main screen, you can see the following function items:

- | | |
|---------------------------|------------------|
| (1) Port Settings | (5) Command Tool |
| (2) Printer Information | (6) Language |
| (3) Printer Configuration | (7) About |
| (4) Printer Function | (8) Exit |

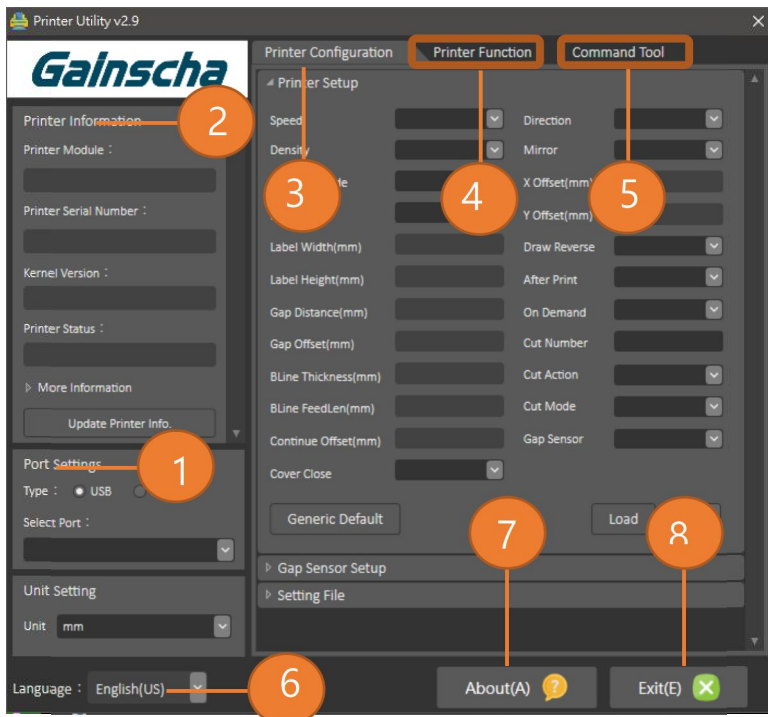

5.1

NOTE: If you need more detailed

information, please refer to

Gainscha official website

<http://www.gainscha.com.tw/>

5.2 Printer Utility(obtain printer status & information)

Ensure that the power supply of the printer is connected and the printer is in the state of starting up, and the printer and the computer are normally connected through the USB cable. Click the **“Load”** button in the Printer Setup section to obtain the current printer Settings, as shown in Figure 5.2:

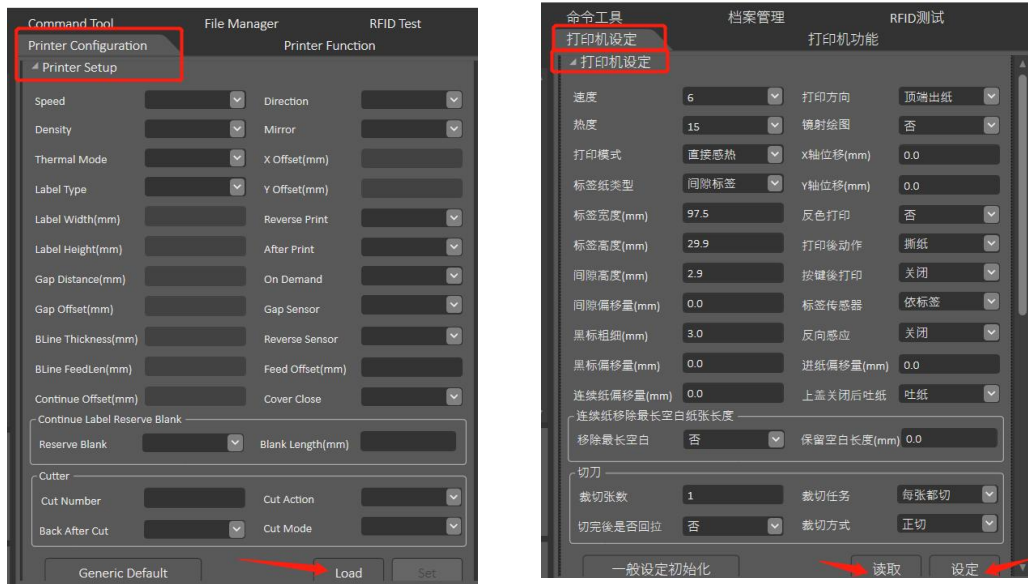

Printer setting can modify the basic settings of the printer. After modification, click the **“Set”** in the lower right corner to complete the setting.

5.3 Printer Setup

1. Click the **Printer Configuration** and **Printer Setup** Can open and close the printer general settings screen.

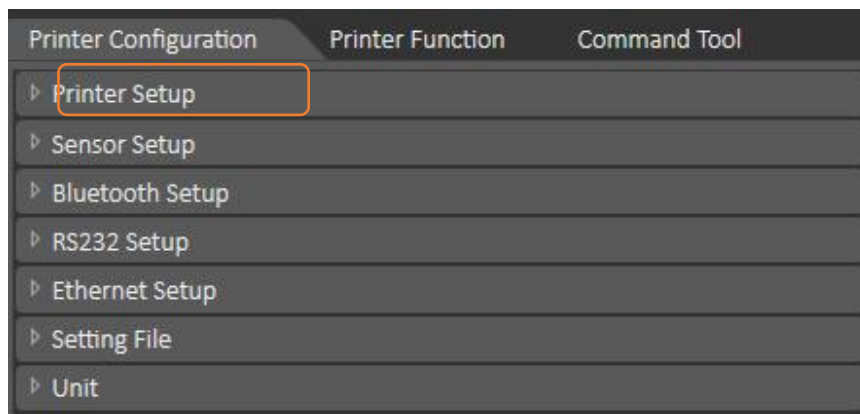

2. Click the **Load** Button to bring out all printer general setting information through the selected

communication interface. Click the **Set** button to write the setting value to the printer (please execute the reading function before writing).

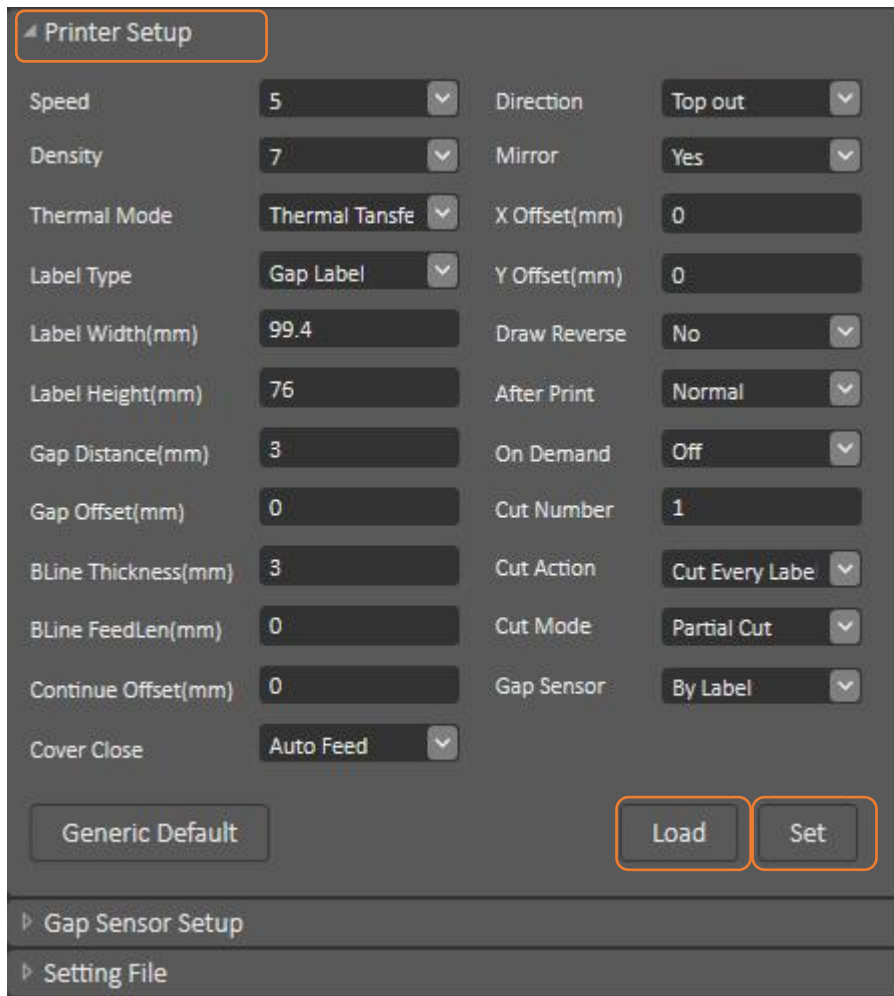

5.3

Printing speed: The speed of printing labels (1-7 inch/s · 1 inch \approx 2.45cm)

Density: The density of printing content. (1-15. The higher the value is, the deeper the print content density is. Set the value according to the actual use. A high density may lead to the fusing of the ribbon.

Thermal Mode: Select printer printing mode (Direct Thermal, Thermal Transfer)

Label Type: Select the label type (Gap Label, Black mark Label, Continue Label)

Label Width(mm): Set the width according to the label used

Label Height(mm): Set the height according to the label used

Gap Distance(mm): The gap distance can be set when using the gap label

Gap Offset(mm): The gap offset can be set when using the special gap label

Black Mark Thickness(mm): The thickness can be set when using the black line label

Black Mark FeedLen(mm): The label offset can be set when using the special black line label.

Direction: Select the direction of print label (Top out or Bottom out)

Mirror: Select whether to print the mirror image

X Offset(mm): Set the offset of the print content in the horizontal direction of the label

Y Offset(mm): Set the offset of the printed content in the vertical direction of the label

Reverse Print: Select whether to reverse color print (Reverse white print, Negative print)

After Print: Select the action after printing (Normal, Tear mode, Peel mode, Cut mode).

The peeling function needs to be used with the peeler, and the cutting function needs to be used with the cutter.

On Demand: Set whether to print after pressing the button

Gap Sensor: Set up the label sensor to detect paper (By label, See-through, Reflective).

The printer can use the corresponding sensor according to the label type under "By label" mode. Usually set as a "See-through" sensor when using gap label, and set as a "Reflective sensor" when using black line label.

Reverse Sensor: Select whether reverse sensor is required

Feed Offset(mm): When using a special label, the extra feed of the label can be set.

Cover Close: Set the action of the printer after the cover is closed (N/A, Auto Feed, Auto Feed + Back). If you choose "N/A", no paper will come out after the cover is closed. If choose "Auto Feed", the printer will calibrate the label and move the label to the starting position of the next label. If choose "Auto Feed + Back", the printer will calibrate the label and come out the label after closing the cover, and then pull back to the printing position.

Reserve Blank: Set whether to leave blank at the end of continuous paper printing.

Select "Yes" to stop printing the content. Select "No" to leave a blank after printing the content.

Blank Length(mm): Set the length of blank content at the end of continuous paper printing

Cut Number: Set the number of consecutive labels reserved after cutting. If the number is set to 1, each label is cut once. If the number is set to "N", cut every N labels. It needs to be used together with the specified cut number in the Cut Action.

Cut Action: Set the working mode of cutting action (Cut Every Label, Cut By Cut Number, Cut Only Last One). When selecting "Cut Every Label" each cutting, each printed label will be cut once; When selecting "Cut By Cut Number" · it is necessary to cooperate with cut number to use together; When choosing "Cut Only Last One", cut once after printing.

Back After Cut: Set whether to pull back the label after cutting

Cut Mode: Select the cutting mode (Forward, Backward). If select "Forward", the paper will be completely cut off, if select "Backward", the middle of the paper will retain a little connection.

5.4 System Setup

This function can be used to modify the simulation language of the printer. The simulation language can be automatically and manually selected. After the selection is completed, click the "Set" to set the current selection. Please refer to following figure

5.4:

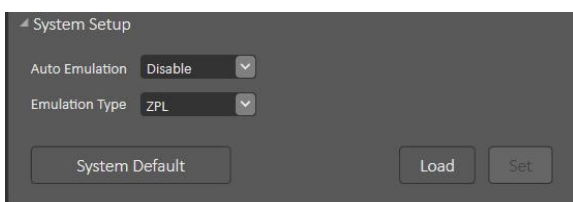

5.4

Automatic: The printer can automatically recognize the command language into the printer, and printing according to the command language.

Manual: You can manually select the instruction language that is sent into the printer. If you use this function, you cannot recognize other instructions except the selected instruction language.

5.5 Gap Sensor Setup

This function can set the sensor sensitivity of the printer to cope with the use of unconventional scenarios. Please refer to following figure 5.5:

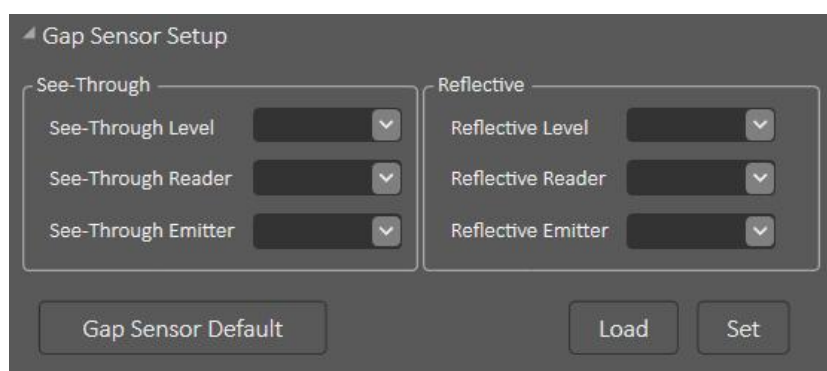

5.5

See-Through Sensor: Sensor signal transmitting terminal and signal receiving terminal on both sides of the paper. The sensitivity can be adjusted by modifying the relevant parameters of the See-Through Sensor.

Reflective sensor: Sensor signal transmitting terminal and signal receiving terminal are on the same side of the paper. By modifying the relevant parameters of the reflective sensor, the sensitivity of the sensor to the black label paper and the detection paper can be adjusted.

5.6 RFID Module Setup

The RFID module can obtain module information and set the RFID module.

Please refer to following figure 5.6:

The figure displays two screenshots of the RFID module setup interface. The top screenshot, titled 'RFID模块', shows the following configuration options: Module Type (UHF-FR3A), Module Version (VC3C8,0000AB10,8), Module Protocol (UHF Gen2/ISO 180), Module Serial Number (0000AB10), RF Output Power (20), and RF Regulation (03: 陆规 920~9). The bottom screenshot, titled 'RFID Module Setup', shows the following configuration options: Type, Version, Protocol, Serial Number, Power Level, and Regulation. Both screenshots include buttons for 'RFID模块初始化' (RFID Module Initialization) and '读取' (Read) in the top screenshot, and 'RFID Module Deafult', 'Load', and 'Set' in the bottom screenshot.

5.6

Type: Information about the module frequency band

Protocol: Displays: The protocol currently supported by the module

Power Level: The power of RFID can be adjusted

Version: Indicates the current module version

Serial Number: Indicates the serial number of the current module

Regulation: The ability to adjust the frequency band of RFID to suit RFID protocols in different countries.

5.7 RFID Setup

This function can set the related functions of RFID. Please refer to following figure 5.7:

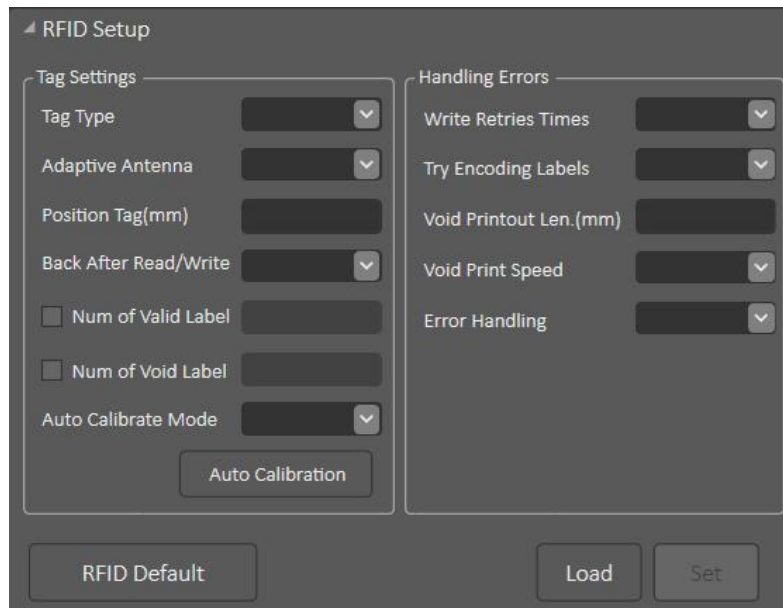

5.7

Tag Settings:

Tag type: Sets the type of tag (for example, Class 1 Gen 2).

Adaptive Antenna: Set the antenna for RFID work.

Position Tag(mm): Set the write position of the RFID tag (Starting from the front edge of the tag). If it is automatic calibration, the Read/Write position after automatic calibration will be displayed.

Back after Read/Write: Set whether the RFID is pulled back after read and write.

Num of Valid Label: Record the number of current RFID valid labels, select the checkbox to clear the value

Num of Void Label: Record the number of current RFID invalid labels, select the checkbox to clear the value

Automatic calibrate mode: Optional RFID automatic calibration mode (Read correction, Write correction)

Auto Calibration: Click it, the printer will make RFID correction by itself.

Handling Errors:

Write Retries Times: Set the number of label rewrites if a write error occurs.

Try Encoding Labels: Set the maximum number of invalid labels that can be repeatedly written to if a write error occurs.

Void Printout Len. (mm): Set the length to print VOID on the label in case of write errors.

Void Print Speed: Set the speed at which VOID is printed on labels in case of write errors.

Error Handling: Set what the printer will do next if a write error occurs (No Action, Pause mode or Error mode)

5.8 Wi-Fi Setup

This function can set the WIFI module in the printer. Please refer to following figure 5.8 and figure 5.9:

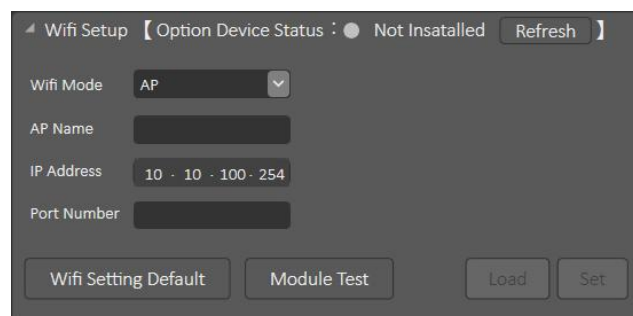

5.8

Module Test: Can detect whether there is Wi-Fi module in the printer.

AP Mode: In this mode, the printer sends WIFI as the router, and the mobile phone connects to the WIFI of the printer as the client.

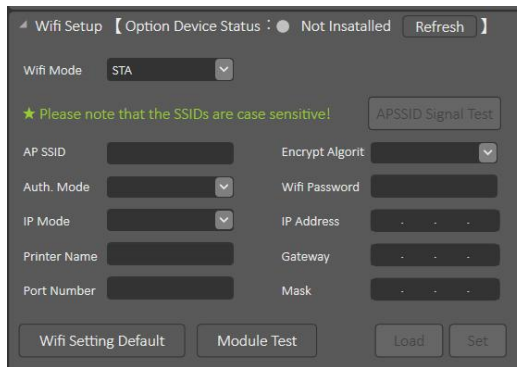

5.9

STA Mode: In this mode, click as a client and connect to WIFI of other routers. After the printer is connected to WIFI, devices on the same LAN as the router can search for the printer and communicate with it. The IP address set cannot conflict with other devices on the LAN.

5.9 Bluetooth Setup

This function can set the Bluetooth module in the printer. Please refer to following figure 5.10:

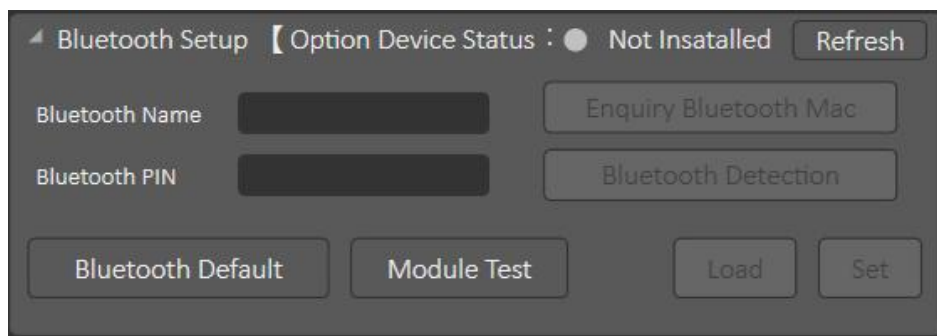

5.10

Module Test: Can detect whether there is Bluetooth module in printer.

Bluetooth Name: Set the printer's own Bluetooth name for external communication:

Bluetooth PIN: Set the PIN code of the printer for external communication.

External devices need to enter this PIN code to communicate with the printer.

5.10 RS232 Setup

This function can set the Serial port (RS232) in the printer. Please refer to following figure 5.11:

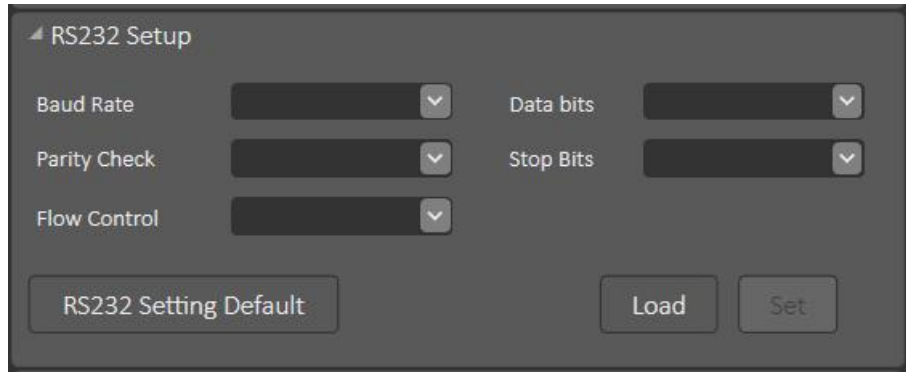

5.11

Baud Rate: Set the baud rate of the serial port. The device that communicates with the printer must be the same as that set for the printer.

Parity Check: Set the parity check.

Flow Control: Control and set the flow of serial port transmission.

Data Bits: Can be set for communication.

Stop Bits: Can be set for communication.

5.11 Ethernet Setup

This function can set the Ethernet port in the printer. Please refer to following figure 5.12:

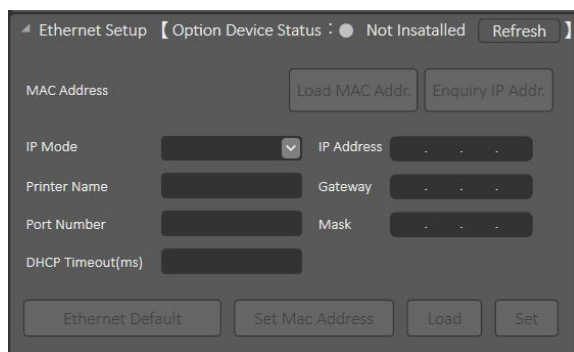

5.12

IP Mode: dynamic and Static IP setting

of printer IP.

IP Address: Sets the IP address of the printer.

Gateway: Enter the gateway IP address of the LAN.

Mask: Set the subnet mask of the printer.

Port Number: set the port number for printer communication.

Note: Only when the IP address of the printer network port is on the same network segment as the connected device, the IP address of the printer cannot conflict with the IP address of other devices in the LAN where the communication device is located.

Ethernet Setup Manual can be downloaded on website directly here:

<https://www.gainscha.com.tw/> or [Click here to view](#)

5.12 Setting File

This function can access files in the current Settings of the printer. Please refer to following figure 5.13:

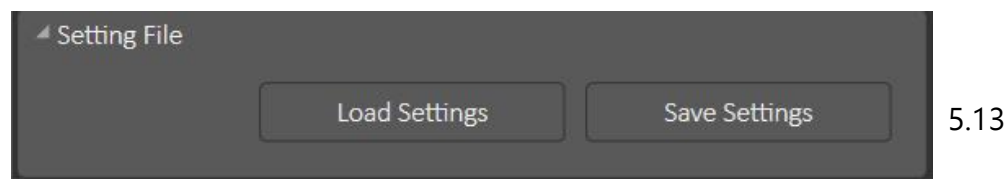

Load Settings: Read storage Settings from files.

Save Settings: Stores the current printer Settings as a document.

5.13 Printer Utility - Command Tool

1. Send Command

The box can input instructions. After clicking the "Send Command", the command can be transmitted to the printer, so that the printer can execute the incoming command. Please refer to following figure 5.14:

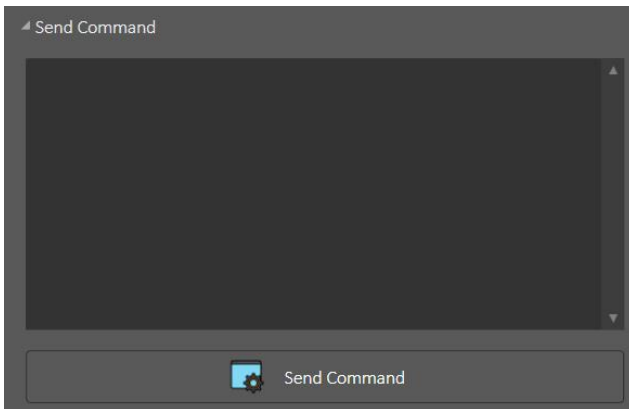

5.14

2. Send File

This command can transmit the instruction document to the printer, and the printer can recognize the instruction and execute the instruction in the document. Please refer to following figure 5.15:

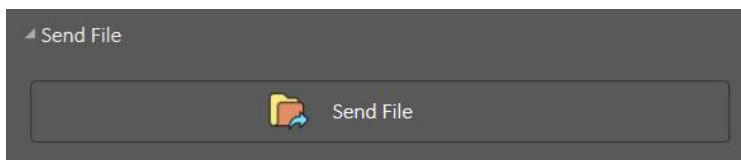

5.15

Click "Send File", the file selection interface will appear, select the corresponding file. The document encoding format should be saved to ANSI, otherwise some instructions will not be recognized.

5.14 Printer Utility – Printer Function

This function can set the functions of the printer. Please refer to following figure

5.16:

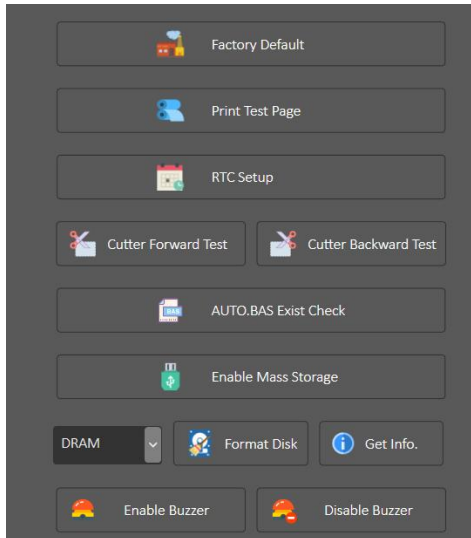

5.16

Factory Default: Click the button to restore the printer to factory Settings.

Print Test Page: Click the button to print test page for printer.

RTC Setup: Click this button to calibrate the time in the printer.

Cutter Forward Test: After clicking this button, the printer cutter can be tangent (full cut) test.

Cutter Backward Test: After clicking this button, the printer cutter can be back cutting (half cutting) test.

AUTO.BAS Exist Check: The AUTO.BAS file in the printer memory can be queried.

Enable Mass Storage: Enables the printer memory. After this function is enabled, the printer cannot print. To print, restart the printer.

Format Disk: Formats the selected printer memory.

Get Info.: Get information about the printer.

Enable Buzzer: Enable the built-in buzzer of the printer

Disable Buzzer: Turn off the built-in buzzer of the printer

5.15 Printer Utility – File Manager

1. File Lists

This function can read or delete files in the corresponding memory device. Please refer to following figure 5.17:

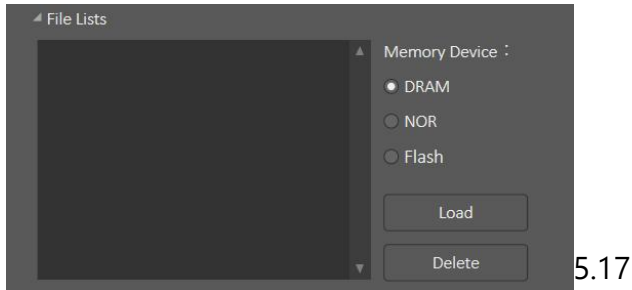

DRAM: After the printer is shut down, the files in this storage area will be deleted automatically.

NOR: This storage area files will be permanently stored in the printer, will not be deleted when the printer shut down, storage mode is random, suitable for storing small files.

Flash: This storage area files are permanently stored in the printer, will not be deleted due to the printer shutdown, storage mode is continuous storage, suitable for large data storage.

2. Add File

This function can pass a document into the printer's memory and use the file when the printer prints

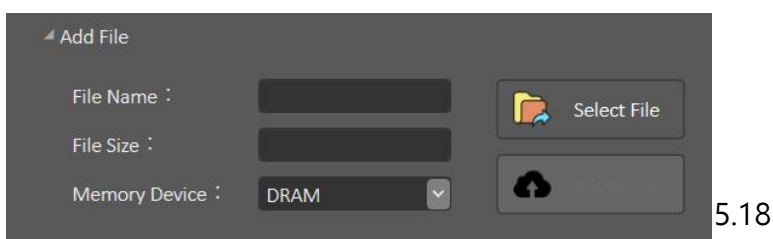

Select File: Click "Select File" and the file selection box will appear. After selecting the corresponding file, the file size will automatically calculate and display the storage size of the file. The selected file cannot exceed the maximum storage capacity of the memory device to be stored.

Memory Device: Select the storage area that the document needs to be imported into. Click the "Upload File" lit up on the right after the selection is completed, and then the document can be sent.

5.16 Printer Utility – Port Settings

On the communication screen, you can select the printer communication port. When using Printer Utility, you need to select the corresponding communication port.

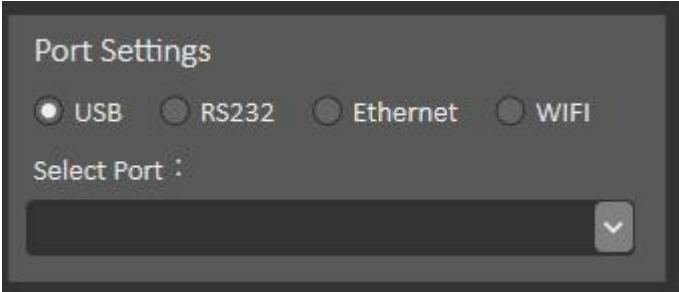

1. USB port

The most commonly used communication port, the maximum transmission rate is higher than the other three communication ports, and the speed is faster.

2. RS232

The maximum data transfer rate is the same as that of Ethernet port and WIFI port. Before using this communication port, you need to know the definition of the serial port

PIN of the device that communicates with the printer and the type of data that the device sends, and set the baud rate to the same as that of the printer.

3. Ethernet

The maximum transmission rate is the same as that of Serial port (RS232) and WIFI port. The printer can be connected to the LAN. When the IP address of the printer does not conflict with the IP address of other devices, other devices can search the printer through the network, and other devices can communicate with the printer on the LAN.

4. Wi-Fi

The maximum transmission rate is the same as that of Serial port (RS232) and Ethernet port. In this port, the printer is used as the communication end to connect to other routing WIFI (STA mode). Under the condition that IP addresses do not conflict, other devices in the LAN can communicate with the printer.

5.17 Printer Utility – RFID Test

RFID Test can write data, read data, unlock, lock, deactivate and other operations on RFID tags. This interface includes Write Data, Read Data, Access Password Setup, Read Access Password, Kill Password Setup, Read Kill Password, Remove Tag sections.

1. Write Data

This section can to write of RFID data, operations should ensure that RFID module on the RFID tag. Please refer to following figure 5.19:

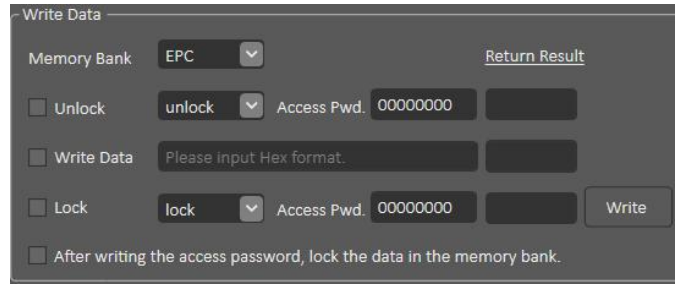

5.19

Memory Bank: Select data write area. (EPC, UESR, TID, some labels do not support UESR and TID area)

Unlock: To unlock or permanently unlock a label, enter the Access Password on the right side.

Write Data: HEX format data entry box in which the user enters the data to be written.

Lock: To lock or permanently lock labels, enter the Access Password to be set on the right.

Write Button: After setting, click "Write" to write the data (The operation is performed only when the check box on the left is selected. If the check box is not selected, the operation will not be performed).

Return Result: The return result of a successful or failed operation. [For details about return error codes, please check Appendix A](#)

2. Read Data

This part can read the data stored in the RFID tag, and the operation should ensure that the RFID tag is on the RFID module. Please refer to following figure 5.20:

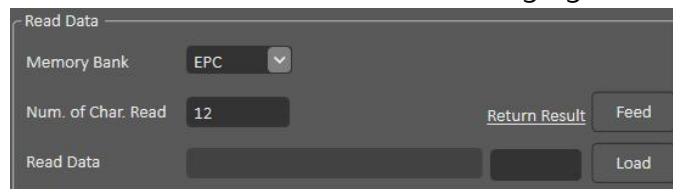

5.20

Memory Bank: Select data read area (EPC, UESR, TID)

Num. of Char. Read: Enter a value (a multiple of 4) based on the number of data to be read.

Read Data: The data box will display the corresponding read RFID data

Return Result: The return result of a successful or failed operation. [For details about return error codes, please check Appendix A](#)

3. Access Password Setup

This part can carry out relevant operation on RFID Access password. Please refer to following figure 5.21:

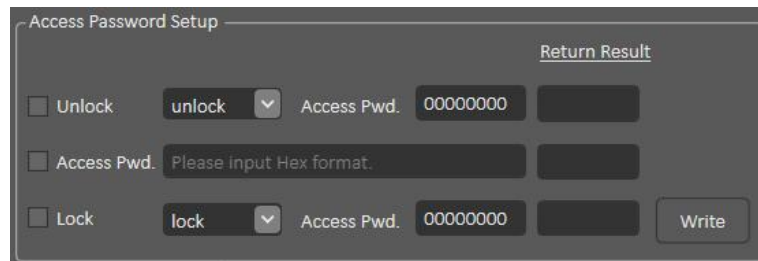

5.21

Unlock: To unlock or permanently unlock the Access password, enter the Access password on the right side to unlock the password.

Access Pwd: HEX format data entry box in which the user enters the Access password to be written.

Lock: To lock or permanently lock the Access password, enter the Access password to be set on the right side.

Write: After setting, click "Write" to write the data (the check box on the left will be checked and the check box step will not be operated if it is not checked).

Return result: The return result of a successful or failed operation. [For details about return error codes, please check Appendix A](#)

4. RFID-Read Access Password

This part can read the Access password. Please refer to following figure 5.22:

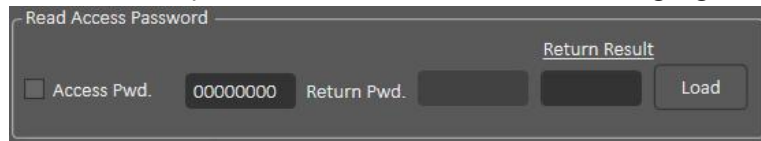

5.22

Access Pwd.: Data Access Password is required to read Access Password.

5. RFID-Kill Password Setup

This part can carry out relevant operation about Kill password. Please refer to following figure 5.23:

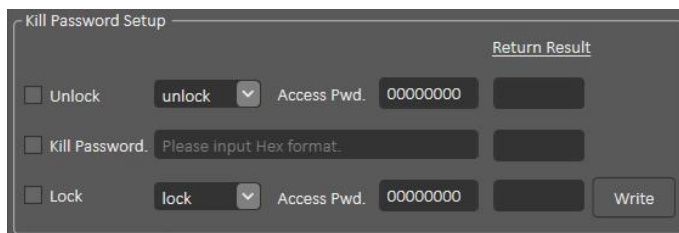

5.23

Unlock: To unlock or permanently unlock the Kill password, enter the

Access password on the right side to unlock the password.

Access Pwd: HEX format data entry box in which the user enters the Kill password to be written.

Lock: To lock or permanently lock the Kill password, enter the Access password to be set on the right side.

Write: After setting, click "Write" to write the data (the check box on the left will be checked and the check box step will not be operated if it is not checked).

Return result: The return result of a successful or failed operation. [For details about return error codes, please check Appendix A](#)

6. Read Kill Password

This part can read Kill Password. Please refer to following figure 5.24:

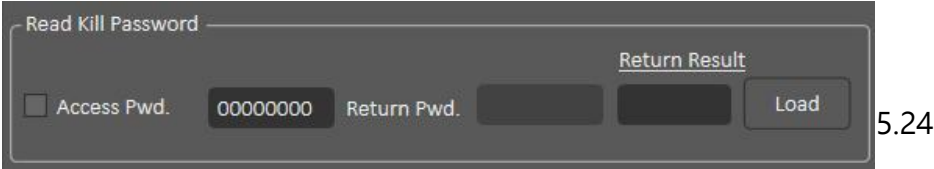

Access Pwd.: Data Access Password is required to read Kill Password.

7. Remove Tag

This part can Remove Tag (Kill). Please refer to following figure 5.25:

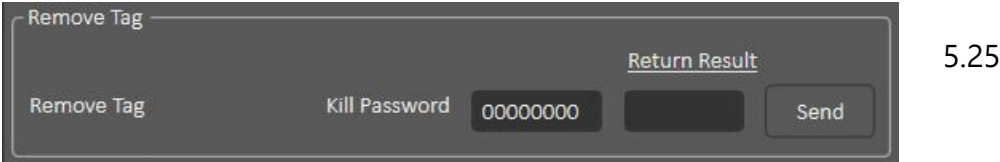





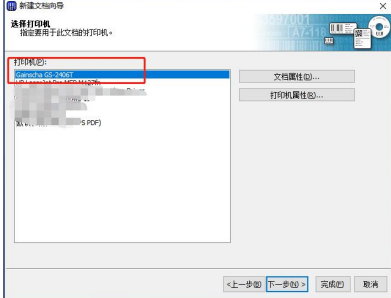
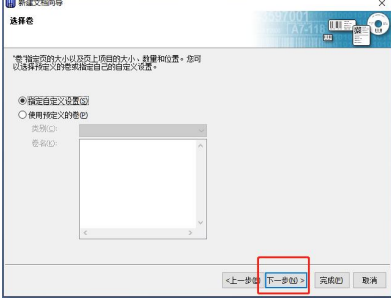

Remove Tag: Enter the Kill Password and click "Send" to deactivate the label. After the label is deactivated, the label cannot be used or read. The operation is irreversible

6. Label editing software - BarTender

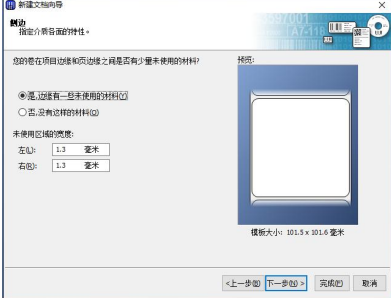
BarTender is an excellent barcode printing software from American Seagull Technology. It is the most used software in the industry. It is the fastest and easiest barcode printing software to design professional and high-quality labels.

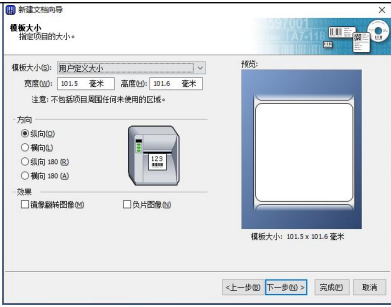

1. Design labels and print contents on labels

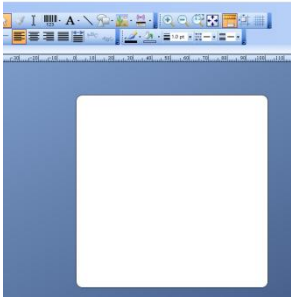
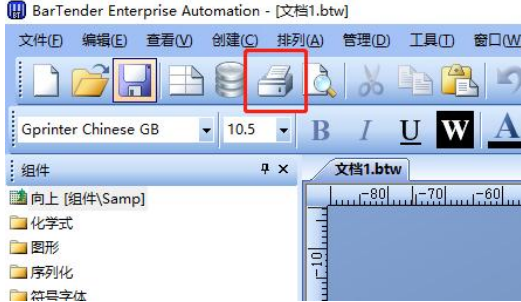
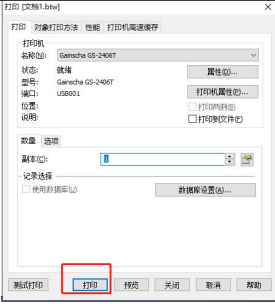
	
<p>1. Open BarTender, select new document, and select a blank templated in the new document</p>	<p>2. Select corresponding printer driver</p>
	
<p>3. Select custom setting and click "Next"</p>	<p>4. Select the corresponding option based on the label used</p>
	
<p>5. Select the corresponding option based on the label used</p>	<p>6. Select the corresponding option based on the label used</p>

	
<p>7. Enter the corresponding label size</p>	<p>8. Select a background based on the label content</p>
	
<p>9. Add barcode or text on the menu bar to design labels.</p>	<p>10. After the design is completed, click the "Print" button submitted or use the shortcut key "Ctrl+P"</p>
	
<p>11. Set relevant parameters before printing and click "Print" to print the designed label.</p>	

2. Import the database

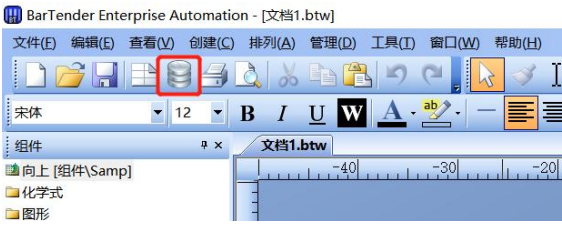
While batch printing is possible, by providing you with a database call method in BarTender. How to print in batches using a database refer to following Excel table as an example:

<p>1. Prepare the required Excel table in. XLS format. The. XLSX format cannot be imported</p>	
<p>Click the "Database Settings" button in the upper left corner, or the shortcut "Ctrl+D"</p>	
<p>3. Click the "Next" button</p>	
<p>4.Database platform select the corresponding Excel and click "Next". (If other database types are used, select the corresponding database file.)</p>	

5. Select the file path and click "Test Connection". Click "Next" when successful.



6. All the table names in the current Excel file will be displayed on the left. Double-click the left mouse button to select the available table and the table will be added to the right. Then click "Finish".



7. By clicking "OK" in the bottom right corner, you have imported the BarTender database and will call it at printing time.

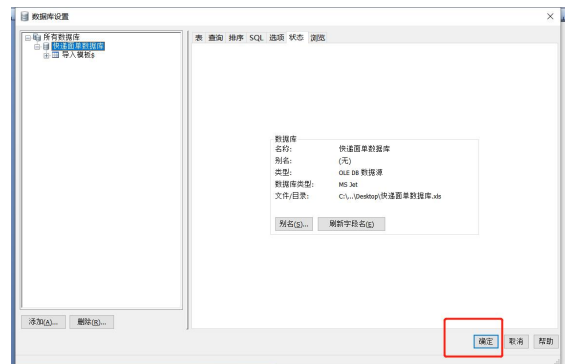

3. Call database batch printing

Next, how to call the database, the database imported in the previous section is used as an example:

1. Create labels you need. In this case, labels in red boxes represent data to be called from the database, and data in non-red boxes represent fixed values.

Double-click or right-click the text box to import the database and choose Properties.

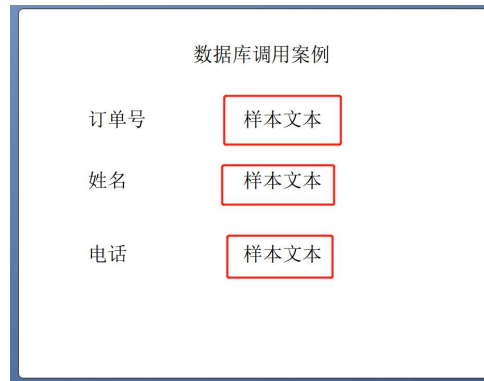

2. Click the data source on the left, then click the select button to the right of the data type, click the dropdown box in the popup window, and select the database field. Then click "Next".

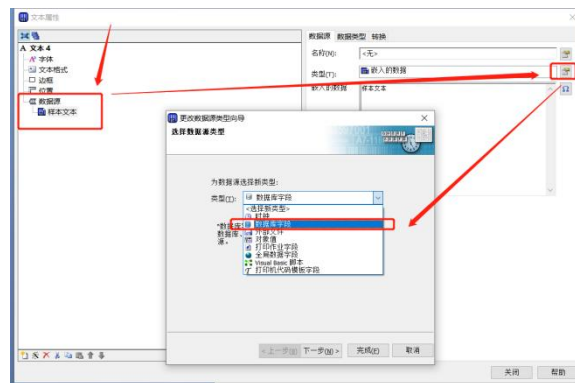

3. In the field name, select the column name that corresponds to the database, and click "Finish". To create multiple database import text boxes, repeat the preceding steps.

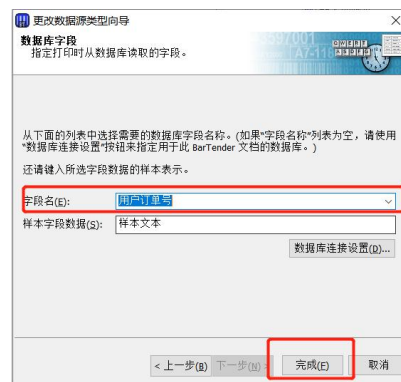

4. After the database call is complete, click the "Print" in the upper left corner, or the shortcut key "Ctrl+P".



5. At this point we can see that the call database option is checked. Copy: The number of sheets to be printed for a single piece of data in

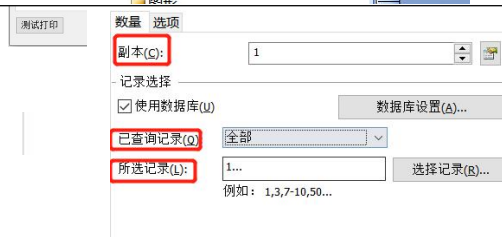

the database.

Select records: You can make a custom selection of the data to be called in the database.

Queried Records: Displays the data records of the currently invoked database.

After the data selection is complete, click print in the lower left corner to print the database called.

4. Batch serialized print

BarTender offers a serialized printing that easily solves the problem of bulk printing.

How to serialize print refer to following Excel table:

1.This case takes serialized printing of barcodes as an example. Only bar codes in labels need serialized output, and other values are fixed. Double-click the bar code or right-click the bar code and choose Properties

序列化打印案例

产品A



2.Select the data source, and select the embedded data in the type.

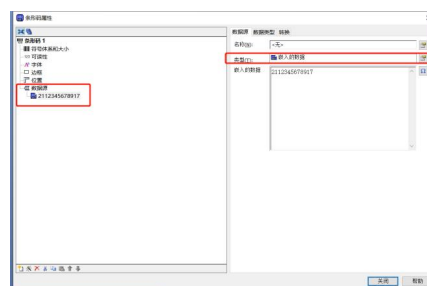

3. Click the top "Transform", then go to the bottom serialization, and click the "Options" button on the right

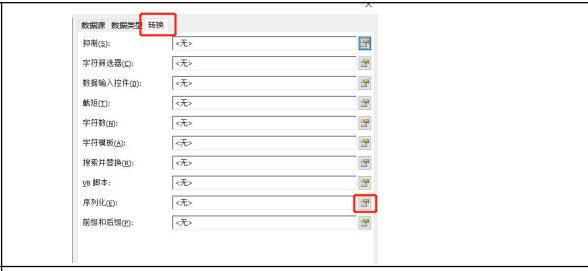

4. Select increment or decrement to start serialization.
 Methods: The ability to serialize the way to choose, such as increasing or decreasing 0-9, A to Z, increasing or decreasing the hex increasing or decreasing.
 Incremental value: The ability to set increment values.
 Click "OK" in the lower right corner to complete the serialization setup.



5. After clicking "Print", relevant settings before printing will pop up:
 Serial number: the number of prints to be serialized
 Copies per serial number: The number of sheets to be printed per serial number

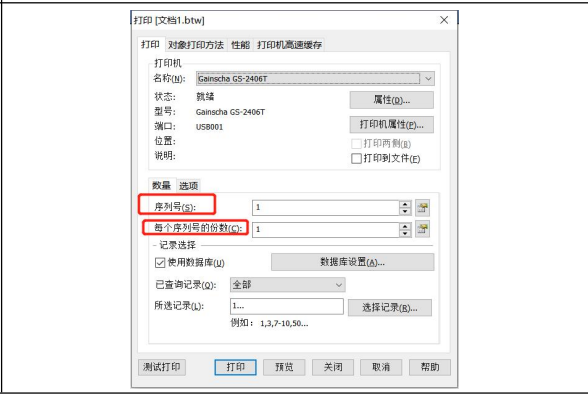

5. Add RFID Tags in BarTender

If you want to use RFID printing, you first need to add RFID tags. How to add RFID tags in BarTender refer to following Excel table.

1. Turn on the BarTender to choose a printer with RFID function. If you choose a printer without RFID function, you cannot open and add RFID label.

2. Click the "RFID" above BarTender and select the corresponding label type to add a label. Repeat this action to add multiple RFID labels.

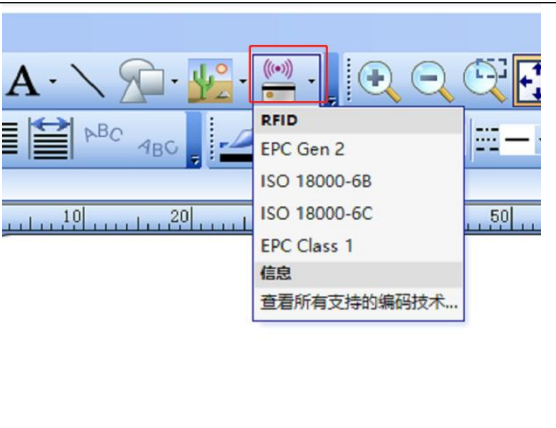

3. Once added, you can see the RFID editor control at the top or right of the tag making page. You can simply edit the label by double-clicking the control or right-clicking the control and clicking properties. [More operations can be explained in Section 6 of this chapter.](#)



6. RFID option in BarTender

The RFID option can set RFID related settings. How the RFID option can be opened in BarTender refer to following Excel table:

1. By opening BarTender to select a printer with RFID function, you cannot open the RFID option if you choose a printer without RFID function.

2. Click the "Print" button in the upper left corner or the shortcut Ctrl+P.

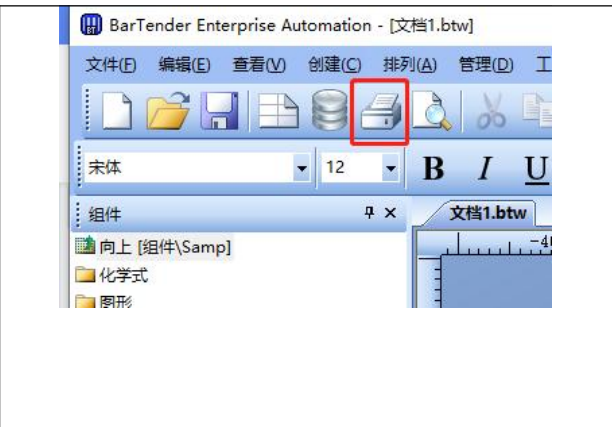

3. Click "Printer properties", then click "Tools" in the popup window, and click the configure drop-down box below to select "RFID" options

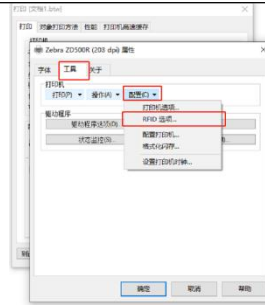

7. The Use of RFID Function

1. ISO 18000-6C protocol introduction

1) Abstract

The ISO18000-6C Electronic Label refers to an electronic label that complies with the ISO18000-6C Air Interface Protocol

2)Data Storage Area

According to the protocol, the label memory is logically divided into four memory banks, each of which can be composed of one or more memory. The four memory banks are:

Reserved Area (4 bytes):

0x00 to 0x1F: Kill Password (1 word, 2 bytes, default 0x0000. It can be modified and locked. After locking, you need to input the Access password to read and write the Kill password)

0x20 to 0x3F: Access Password (1 word, 2 bytes, default 0x0000. It can be modified and locked. After locking, you need to input the Access password to read and write the Access password)

EPC Storage Area:

0x00 to 0x0F: CRC-16 (Cyclic redundancy calibration, 16 bit)

0x10 to 0x1F: Protocol-Control(PC) (EPC backscatter information)

0x20 Start: EPC (Data Storage Area)

TID Storage Area:

Store tag ID information (Each tag has a unique ID)

USER Area:

The storage length is the largest of the four memory banks, depending on the material, and some do not have user storage, storing user-specified data. The storage is organized as user defined.

2. RFID Driver Installation

<p>1.Open Printer Utility to view the current USB port number.</p>																	
<p>2. Download the BarTender seagull driver and set the specified port to the one you found in the PrinterUtility.</p>	<table border="1"> <thead> <tr> <th>端口</th> <th>类型</th> </tr> </thead> <tbody> <tr> <td>COM5:</td> <td>串行端口 (9600:8N1)</td> </tr> <tr> <td>FILE:</td> <td>本地端口</td> </tr> <tr style="background-color: #0070C0; color: white;"> <td>USB001</td> <td>USB 虚拟打印机端口</td> </tr> <tr> <td>USB002</td> <td>USB 虚拟打印机端口</td> </tr> <tr> <td>USB003</td> <td>USB 虚拟打印机端口</td> </tr> <tr> <td>USB004</td> <td>USB 虚拟打印机端口</td> </tr> <tr> <td>USB005</td> <td>USB 虚拟打印机端口</td> </tr> </tbody> </table>	端口	类型	COM5:	串行端口 (9600:8N1)	FILE:	本地端口	USB001	USB 虚拟打印机端口	USB002	USB 虚拟打印机端口	USB003	USB 虚拟打印机端口	USB004	USB 虚拟打印机端口	USB005	USB 虚拟打印机端口
端口	类型																
COM5:	串行端口 (9600:8N1)																
FILE:	本地端口																
USB001	USB 虚拟打印机端口																
USB002	USB 虚拟打印机端口																
USB003	USB 虚拟打印机端口																
USB004	USB 虚拟打印机端口																
USB005	USB 虚拟打印机端口																
<p>3.After the installation is complete, the current USB port driver is deleted and a corresponding driver model is installed.</p>	<p style="text-align: center;">Amore detailed installation process can be found in Section 2 of Chapter 3</p>																

3. RFID Calibration

1)Auto Calibration

Method One:

In standby state, long press the FEED button (About 4s) until the printer automatically removes paper, then release, and the printer automatically carries out paper detection calibration. When the paper is stopped and the blue light is on, the paper detection calibration is completed.

Method Two:

Open Printer Utility, click "RFID UHF Setup" in the "Printer Configuration", then click "Auto Calibration", and the printer can automatically conduct paper detection calibration. After stopping and the blue light is constant, it means that the paper detection calibration is completed.



Usage Scenarios:



After the first installation or the replacement of different specifications of paper, please carry out paper detection correction, so that the printer can accurately detect the best writing position of paper.

Cancel correction:

Method 1: Press the FEED button twice

Method 2: Open PrinterUtility and find the "Gap Sensor Setup" in the Printer Configuration, and then click the "Gap Sensor Default".

2) Manual Calibration

<p>Method one:</p> <p>From Bartender, press Ctrl+P to enter the pre-print interface, click "Printer Properties", select the Configuration drop-down box in the Tools section, select RFID options, find the transceiver location in the General menu, you can manually set the probe read/write location (starting from the label front). As shown in the picture on the right:</p>	
<p>Method 2:</p> <p>Open PrinterUtility, click RFID UHF Setup in the Printer Configuration and then input the value for use in the read/write position box (starting from the front of the label). As shown in the picture on the right:</p>	

3) Calibration Failure

Calibration will stop automatically if the UHF tag cannot be detected for a certain distance.

Possible causes:

1. Insert other non-UHF band labels, such as HF, etc.
2. Insert a non-RFID tag.

3.1 Set Access Password

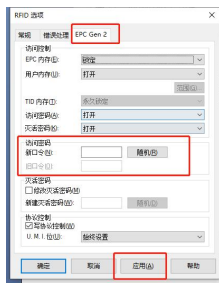

Method one: Set the Access Password in BarTender

Open BarTender and add the RFID tag ([Detailed in Chapter 6, Section 5](#)) After adding the RFID tag, open the RFID option ([Detailed in Chapter 6, Section 6](#)). In EPC Gen 2, select an area to lock and the Access password box will change from dark to light. Enter Access Password in the input box and click "Apply" or "OK" below

Method Two: Set Access Password in PrinterUtility



Click the "Access Password Setup" in PrinterUtility RFID Test plate for setting ([Detailed explanation of the plate can be seen in Section 8 of Chapter 5](#)), enter the access password to be written in the input box of "Access Pwd.", and then click the "Write" button, [return error code details can be seen in Appendix A.](#)

3.2 Set Kill Password

Method 1: Set Kill Password in BarTender

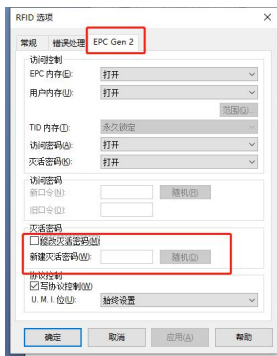

Open BarTender and add the RFID tag ([the details are described in Chapter 6, Section 5](#)). After adding the RFID tag, open the RFID option ([details are described in Chapter 6, Section 6](#)). In EPC Gen 2, check the button to change the Kill password and enter the Kill password in the password box. Click "Apply" or "OK" below. After the Kill command is executed, labels die permanently and cannot be used any more. Labels that are not configured with the Kill Password cannot be killed.

Method Two: Set Kill Password in PrinterUtility





It can be set in the Kill Password Setup area of PrinterUtility RFID Test plate ([detailed explanation of the plate can be referred to in Section 8 of Chapter 5](#)). Enter the Access password to be written in the input box of Access Pwd., then click the "Write" button on the lower right corner. [Refer to Appendix A for details of returned error code.](#)

8. RFID data is written in BarTender

8.1 Writes Open Data in EPC Area

Method one: Write data in BarTender

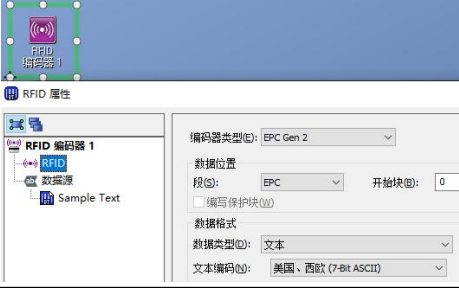
Open Data can be written and read on the label without Access password. In this case, RFID write is made on the label in ASCII format with the content "EXAMPLE ONE". By BarTender, the steps are as follows

<p>1. Open BarTender, select the corresponding printer model, and click the RFID icon in the upper view bar to add the RFID label</p>	
<p>1. Double-click the RFID tag with the left mouse button to appear the RFID data editing tag. In the RFID option below the RFID Encoder, the data type can be modified (Text or Hex).</p>	
<p>3. In the Data Source option, you can edit the data to be written. Data needs to be written according to the RFID label type. Data cannot be written outside the storage scope of the RFID tag.</p>	
<p>4. At this point, the Open Data required to write is set, then only need to edit the RFID tag surface printed content. The visible content and read data on the label are shown on the right</p>	



Method Two: Write data in PrinterUtility

Can be set in Write Data Area in PrinterUtility RFID Test plate ([Detailed explanation of the plate can be referred to in Chapter 5 section 8](#)). Enter the access password to be

written in the Write Access Pwd. input box, click the “Write” button on the lower right corner to write. [Return error code details can be referred to Appendix A.](#)

8.2 Rules for writing data in LOCK state

Area	Access Password Check whether the Access Password is required to write data in LOCK state
Access Password	Need
Kill Password	Need
EPC Data Area	Need
TID Storage Area	Need
User Storage Area	Need

8.3 EPC Area Writes Locking Data



Method one: Write Lock Data in BarTender

Lock Data writing needs to set access password. This case will lock write RFID tag EPC area:

Open BarTender and add the RFID tag (Detailed in Chapter 6, Section 5). After adding the RFID tag, open the RFID options (Detailed in Chapter 6, Section 6) in the EPC Gen 2 section, set the EPC area to lock and enter the password in the Access Pwd. box

with a 4-byte HEX code. Click “OK” or “Apply” button, then print the required content on the label design page to print.

8.4 Data read rule in LOCK state

Using the LOCK command, you can LOCK the saved data area. After the LOCK, data cannot be modified without the access password.

Area	Access Password Check whether Access Password is required to read data in LOCK state
Access Password	Need
Kill Password	Need
EPC Data Area	No
TID Storage Area	NO
User Storage Area	NO

9. Other RFID Function Setting

Other RFID function Settings can assist the printer to better complete RFID operations. There are two modes of operation. While the PrinterUtility Settings ([details are available in Chapter 5, Section 3](#)) and the RFID options in BarTender ([how to open the RFID options is available in Chapter 6, Section 6](#)). This section introduce the Function Settings of the RFID options. Please refer to following figure 7.7.1 and 7.7.2:

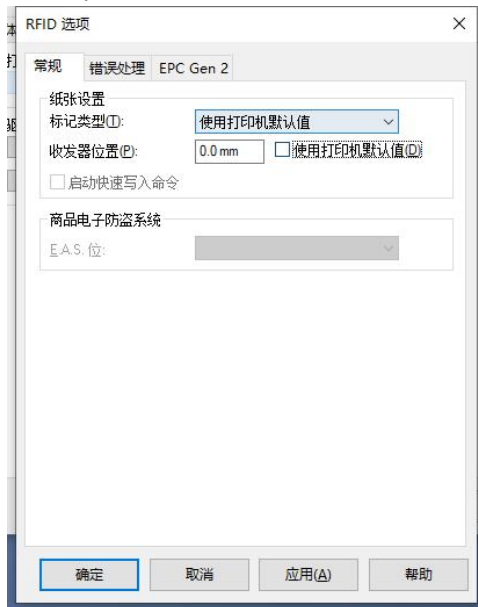

7.7.1

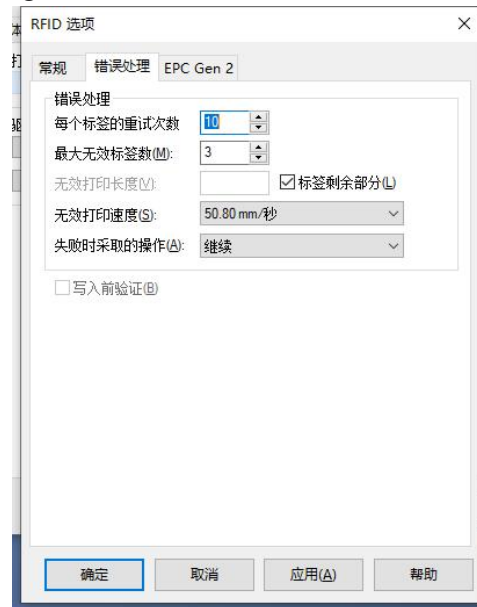

7.1.2

Tag type: Sets the type of tag (for example, Class 1 Gen 2).

Transceiver position: Sets the write position of the RFID tag (starting from the front edge of the tag).

Retries per label: Sets the number of times a label is rewritten if a write error occurs.

Maximum number of invalid labels: Sets the maximum number of invalid labels that can be repeatedly written to if a write error occurs.

Invalid print length: Sets the length to print VOID on the label in case of write errors.

Invalid print speed: Sets the speed at which VOID is printed on labels in case of write errors.

Action taken when invalid: Sets what happens next to the printer when a write error occurs (Continue, Stop or Do no operation)

10. Printer Program Upgrade

Gainscha printers support program upgrade, if you need to upgrade, please contact relevant personnel for upgrade guidance.

1. Printer status upgrade

1.1 Prepare for the upgrade

1. The printer is correctly connected to the computer through USB interface;
2. The printer is normally started and in the ready state;
3. Prepare the printer program file (in .gdac or .gpl format) and program upgrade tool FWTool.

1.2 Start the upgrade

Each version of the printer program is different, this case uses model GA-3406T as an example:

1. Open FWTool and check whether the corresponding port is correct. Click "Get Printer Info." to obtain the current printer information.



2. Click "Open File"



3. When selecting the file, select GDAC or GPL file, then select the corresponding upgrade file, and click the lower right corner to open it.

4. After the selection is complete, click "Upgrade" on the lower left corner to upgrade, and the machine will automatically restart after the upgrade is completed (do not power off or perform other operations during

Note: 200DPI model cannot be upgraded to

300DPI model, 300DPI model cannot be upgraded to 200DPI model. Please confirm the DPI of the printer to be upgraded and select the correct program

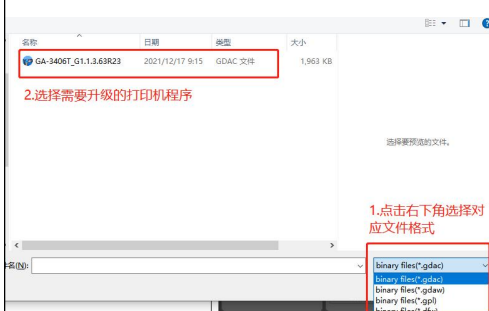

the printer upgrade).



2. Debug mode upgrade program

When the printer can obtain port information, but cannot run abnormally, you can choose to enter the debugging mode for upgrade.

1) Prepare for the upgrade

1. The printer is correctly connected to the computer through USB interface;
2. The printer is **shut down**.
3. Prepare printer program files in .dfw format and program upgrade tool FWTool.

2) Start the upgrade

Each version of the printer program is different, this case uses model GA-3406T as an example:

1. **Long press** the FEED button to turn on the power switch and observe the color change of the light. The light will undergo the following changes successively:

2. Open FWTool, select the **serial port**, and check whether the port settings are correct, select the "BootUpdating Mode" as well.

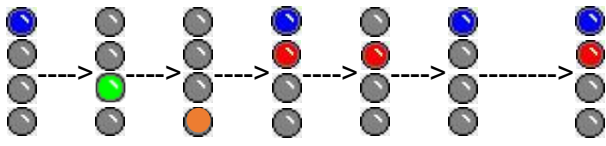

When the light is red and blue steady on for the **second time**, release the button and the printer light will be off. Press the FEED button **once** and the blue light will strobe-flash, that is to enter the debugging mode.



3. Click "Open File"



4. In the lower right corner, select a .dfw file and click to open the file

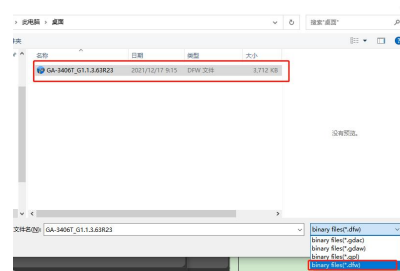

5. After selecting, click "Upgrade" button on the lower left corner.



6. If the following popup window occurs, click "Update"

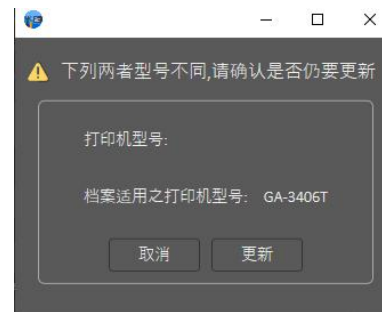

Note: Completion of sending data does not mean completion of update. After data is sent, wait for the printer to update and restart itself. No other operations are required.

Appendix A:

Printer Utility Return Code

Return result error code description table			
Error code	Description	Error code	Description
1	RFID module initialization failed	104	Nonspecific error
2	Read error	105	CRC error
3	Command parameter error	106	An error occurred while writing, sending back the number of written words
5	Operation timed out	107	If the Tag returns an error, add the error code to the number of words that have been written
6	Module return failure	108	No label exists
100	Others error	109	Instruction format error
101	Out of storage range	110	Failed to set power supply strength
102	The storage area is locked	111	Failed to set RF regulations
103	Lack of power		

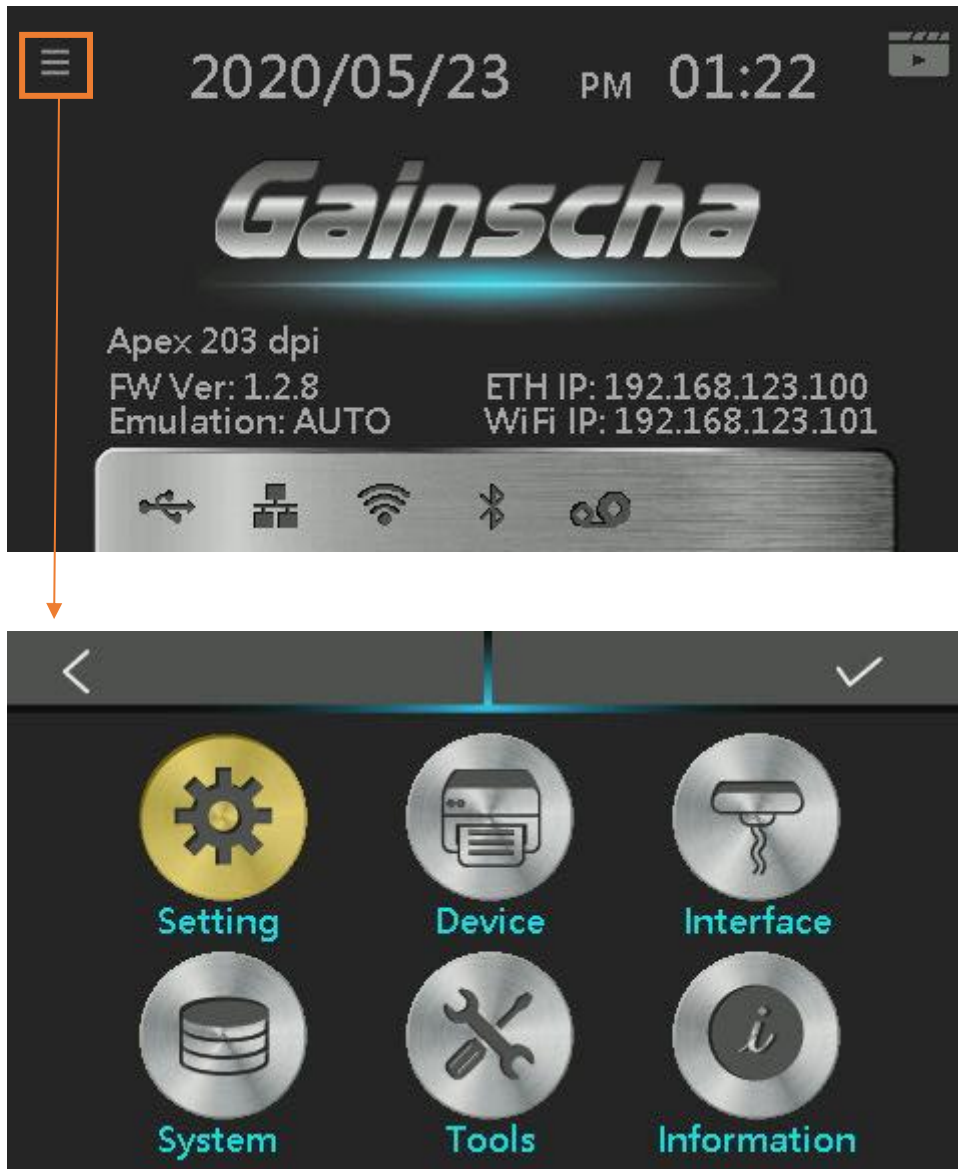

11. LCD Menu Function for GA-2408T , GA- 3406T, GA-6404T Series

11.1 Enter the Menu

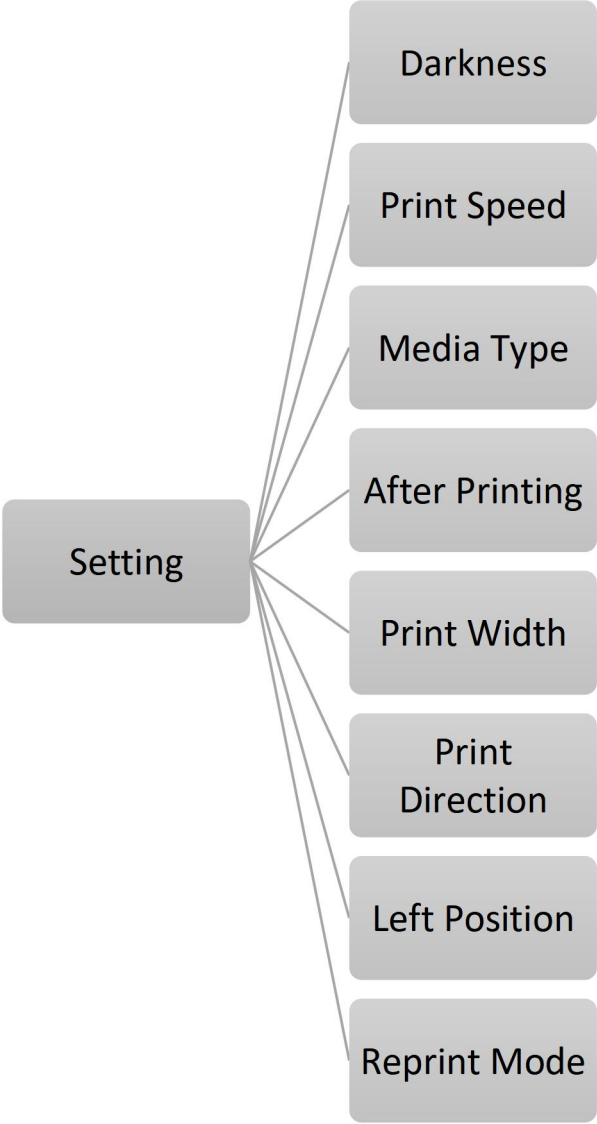

11.2 Menu Overview

There are 6 categories for the menu. You can easily set the settings of the printer without connecting the computer. Please refer to below for more details.

Button icon	function
	<p>This "Setting" option can set the printer function.</p>  <pre>graph LR; Setting[Setting] --- Darkness[Darkness]; Setting --- PrintSpeed[Print Speed]; Setting --- MediaType[Media Type]; Setting --- AfterPrinting[After Printing]; Setting --- PrintWidth[Print Width]; Setting --- PrintDirection[Print Direction]; Setting --- LeftPosition[Left Position]; Setting --- ReprintMode[Reprint Mode];</pre>
	<p>This "Device" option can set the device function.</p>

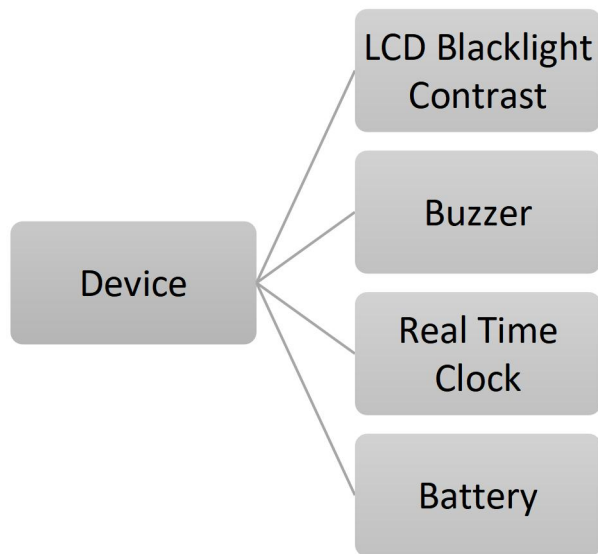

This "Interface" option can set the interface.

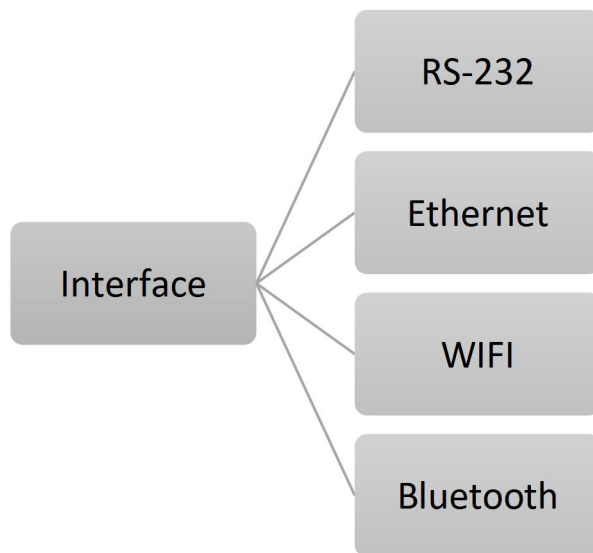

This "System" option can set the system parameters.

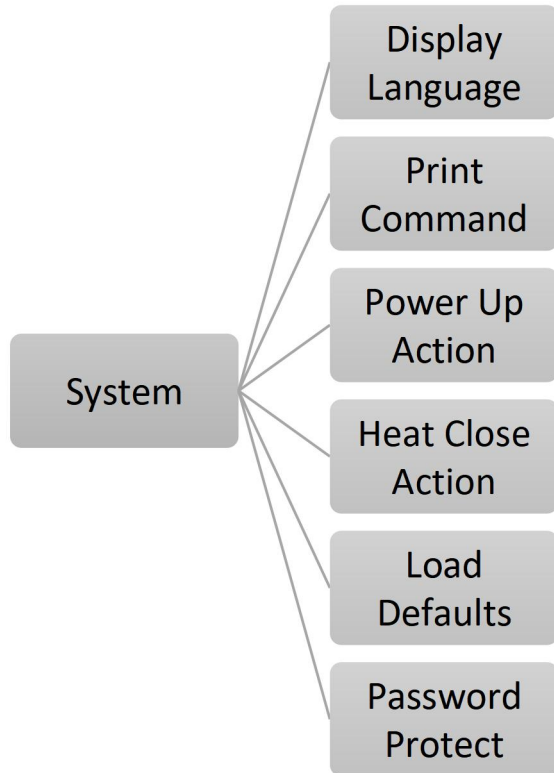

This "Tools" option can set the printer operation tool.

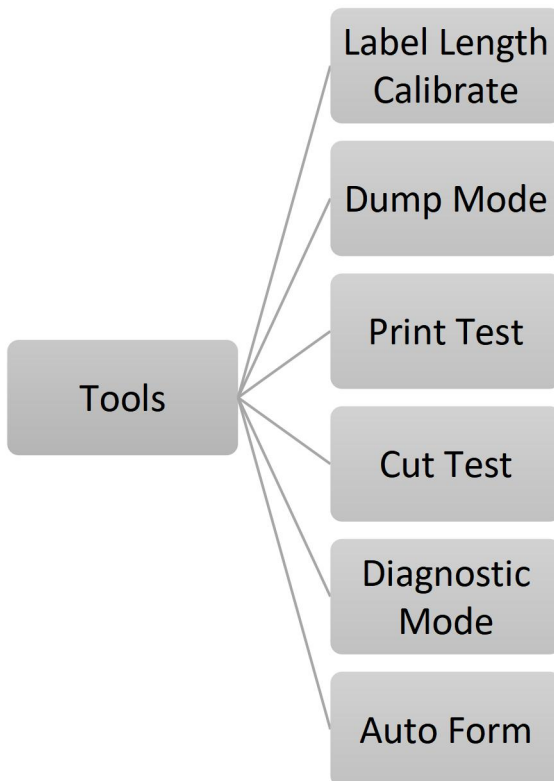

















This "Information" option can inquire about the printer information.

Information

11.3 Error and screen message introduction

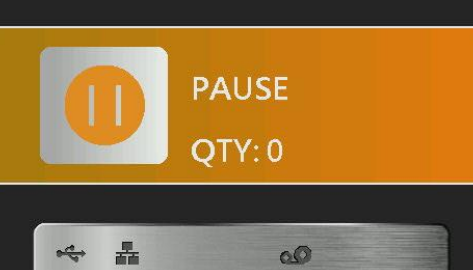
Screen message	Description
	This message is head open.
	This message is ribbon out.
	This message is gap out.

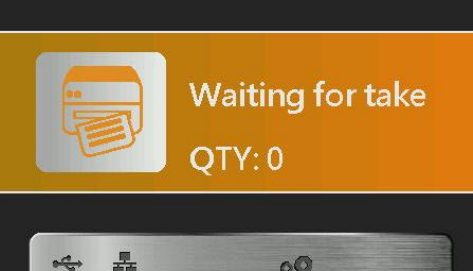
 <p>Error Label Out QTY: 0</p>	<p>This message is label out.</p>
 <p>Error No TPH QTY: 0</p>	<p>This message is no print head.</p>
 <p>Error No Cutter QTY: 0</p>	<p>This message is no cutter.</p>
 <p>Error No Peeler QTY: 0</p>	<p>This message is no peeler.</p>
 <p>Error Cutter Jam QTY: 0</p>	<p>This message is cutter jam.</p>
 <p>Error Memory Error QTY: 0</p>	<p>This message is memory error.</p>

	<p>This message is label error.</p>
	<p>This message is print head over heat.</p>
	<p>This message is pause.</p>
	<p>This message is demand.</p>
	<p>This message is waiting for take.</p>
	<p>This message is printing.</p>

12. Communication interfaces

1) USB (A Type)

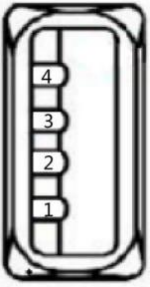

Pin No.	Pin Name
1	VBUS
2	D-
3	D+
4	GND

2) USB (B Type)

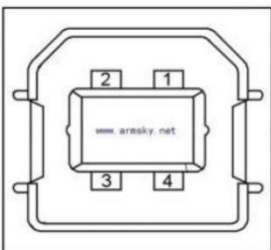

Pin No.	Pin Name
1	VBUS
2	D-
3	D+
4	GND

3) Serial Port

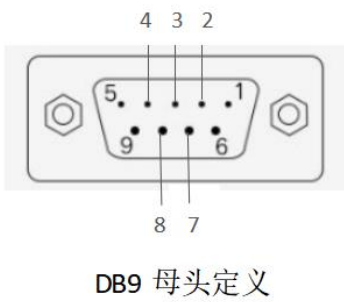

Pin No.	Pin Name	Description
1	-	-
2	TXD	Transmit Data
3	RXD	Receive Data
4	Connect to Pin6	Equipment to Judge
5	GND	System Ground
6	Connect to Pin4	Equipment to Judge
7	CTS	Clear to Send
8	RTS	Request to Send
9	-	Reserve (No output)

4) Ethernet Port

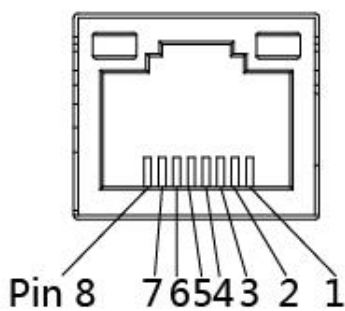

Pin No.	Pin Name
1	TX+
2	TX-
3	RX+
4	-
5	-
6	RX-
7	-
8	-

13. Troubleshooting

13.1 Common Problems

The following guide lists the most common problems that may be encountered when operating this bar code printer. If the printer still does not function after all suggested solutions have been invoked, please contact the Customer Service Department of your purchased reseller or distributor for assistance.

Problem	Possible Cause	Recovery Procedure
Power indicator does not illuminate.	<ul style="list-style-type: none"> ● The power cord is not properly connected. 	<ul style="list-style-type: none"> ● Plug the power cord in printer and outlet. ● Switch the printer on.
Out of ribbon	<ul style="list-style-type: none"> ● Out of ribbon. ● The ribbon installation path is incorrect. 	<ul style="list-style-type: none"> ● Install new ribbon. ● Follow the steps for installing the ribbon to reinstall.
Out of paper	<ul style="list-style-type: none"> ● Out of paper. ● The paper installation path is incorrect. ● Gap / black mark sensor detection is incorrect. 	<ul style="list-style-type: none"> ● Install new paper. ● Follow the steps for installing the paper to reinstall. ● Recalibrate the label sensor.
Paper jam	<ul style="list-style-type: none"> ● Gap / black mark sensor detection is incorrect. ● The label size is set incorrectly. ● Label may be blocked inside the printer. 	<ul style="list-style-type: none"> ● Recalibrate the label sensor. ● Set the correct label size. ● Cleaning the inside of the printer.
Unable to print	<ul style="list-style-type: none"> ● Cable is not well connected to serial or USB interface or parallel port. 	<ul style="list-style-type: none"> ● Re-connect cable to interface. ● Change a new cable. ● Ribbon and media are not compatible. ● Verify the ribbon-inked side. ● Reload the ribbon again. ● Clean the print head. ● The print density setting is incorrect. ● Print head's harness connector is not well connected with printhead. Turn off the printer and plug the connector again.

Poor print quality	<ul style="list-style-type: none"> ● Ribbon and media is loaded incorrectly. ● Dust or adhesive accumulation on the print head. ● Print density is not set properly. ● Printhead element is damaged. ● Ribbon and media are incompatible. 	<ul style="list-style-type: none"> ● Reload the supply. ● Clean the print head. ● Clean the platen roller. ● Adjust the print density and print speed. ● Run printer self-test and check the print head test pattern if there is dot missing in the pattern. ● Change proper ribbon or proper label media. ● The print head mechanism does not latch the print head properly.
Skip labels when printing	<ul style="list-style-type: none"> ● Label size is not specified properly. ● Sensor sensitivity is not set properly. ● The media sensor is covered with dust. 	<ul style="list-style-type: none"> ● Check if label size is setup correctly. ● Calibrate the sensor by Auto Gap or Manual Gap options. ● Clear the GAP/Black mark sensor by blower.
The printing position of small label is incorrect	<ul style="list-style-type: none"> ● Media sensor sensitivity is not set properly. ● Label size is incorrect. ● The vertical offset setting in the driver is incorrect. 	<ul style="list-style-type: none"> ● Calibrate the sensor sensitivity again. ● Set the correct label size and gap size. ● If using the software BarTender, please set the vertical offset in the driver.
Missing printing on the left or right side of label	<ul style="list-style-type: none"> ● Wrong label size setup. 	<ul style="list-style-type: none"> ● Set the correct label size.
Wrinkle problem	<ul style="list-style-type: none"> ● Ribbon installation is incorrect. ● Media installation is incorrect. ● Print density is incorrect. ● Media feeding is incorrect. 	<ul style="list-style-type: none"> ● Please set the suitable density to have good print quality. ● Make sure the label guide touch the edge of the media guide.
Gray line on the blank label	<ul style="list-style-type: none"> ● The print head is dirty. ● The platen roller is dirty. 	<ul style="list-style-type: none"> ● Clean the print head. ● Clean the platen roller
Irregular printing	<ul style="list-style-type: none"> ● The printer is in Hex Dump mode. 	<ul style="list-style-type: none"> ● Turn off and on the printer to skip the dump mode.

14. Maintenance

This session presents the clean tools and methods to maintain your printer.

1. Please use one of following material to clean the printer.
 - Cotton swab
 - Lint-free cloth
 - Vacuum / Blower brush
 - 100% ethanol
2. The cleaning process is described as following,

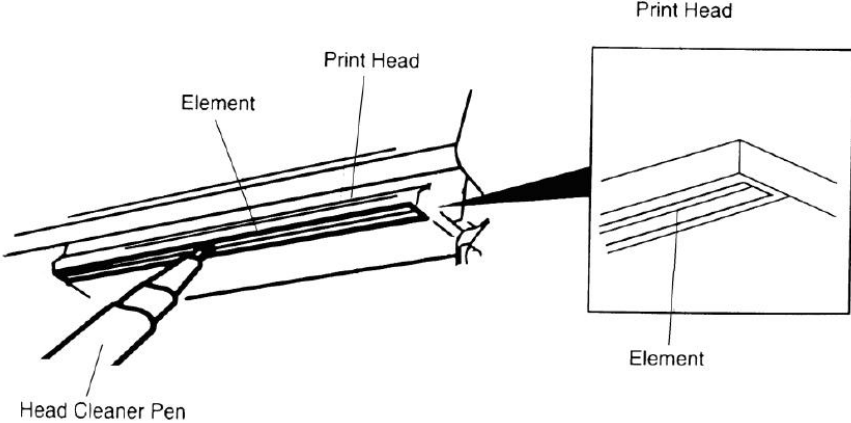
Printer Part	Method
Print Head	<ol style="list-style-type: none"> 1. Always turn off the printer before cleaning the print head. 2. Allow the print head to cool for a minimum of one minute. 3. Use a cotton swab and 100% ethanol to clean the print head surface. 
Platen Roller	<ol style="list-style-type: none"> 1. Turn the power off. 2. Rotate the platen roller and wipe it thoroughly with 100% ethanol and a cotton swab, or lint-free cloth.
Tear Bar/Peel Bar	Use the lint-free cloth with 100% ethanol to wipe it.
Sensor	Compressed air or vacuum
Exterior	Wipe it with water-dampened cloth
Interior	Brush or vacuum

NOTE:

- Do not touch printer head by hand. If you touch it careless, please use ethanol to clean it.
- Please use 100% Ethenol.DO NOT use medical alcohol, which may damage the printer head.
- Regularly clean the print head and supply sensors once change a new ribbon to keep printer performance and extend printer life.

The maximum printing ratio per dot line is 15% for this printer. To print the full web black line, the maximum black line height is limited to 40 dots, which is 5mm for 203 DPI resolution printer and 3.3mm for 300 DPI resolution printer.

15. Revise History

Date	Version	Content
2020/8/10	Ver.1.0.1	Modify chapter 4.2 Power-on Utilities Modify GA-2406TM / GA-3405TM renamed to GA-2408TM / GA-3406TM Delete Extended plate in chapter 1.2.2 Printer Optional Features Delete chapter 3.4.3 External Label Roll Mount Installation (Option) Modify 4.1 Regular Button Function
2021/1/15	Ver.1.0.2	Modify chapter 1.2.1 Printer Standard Features
2021/1/15	Ver.1.0.3	Modify GA-2408TM / GA-3406TM renamed to GA-2408T / GA-3406T
2021/1/20	Ver.1.0.4	Modify GA-2406T / GA-3405T renamed to GA-2408T / GA-3406T Modify chapter 1.2.1 Printer Standard Features Modify chapter 4.1 Regular Button Functions
2021/3/19	Ver.1.0.5	Modify 104 mm (4.09 ") to 104 mm (4.1 ") and 106.7 mm (4.2 ") to 108.4 mm (4.27 ")
2021/8/16	Ver.1.0.6	Add warning slogan
2021/9/28	Ver.1.0.7	Modify chapter 3.5 Loading the Cutter Modify chapter 3.6 Loading the Peeler
2021/12/21	Ver.1.0.8	Add 600 dpi specification Add warning slogan(FCC radiation exposure statement) Add RFID specification
2022/4/23	Ver.1.0.9	Add communication interfaces
2022/6/15	Ver.1.1.0	Add The Antenna part 2.25 Add chapter 5-10 RFID function