1000BASE-PX20+/++/+++

EPON OLT SFP Transceiver

Product Features

- SC BIDI SFP Single Mode Transceiver
 - Compliant with SFP MSA and SFF-8472
 - Single +3.3 Power Supply, Hot-pluggable
 - Complies with Telcordia (Bellcore) GR-468-CORE
 - Class I laser safety standard IEC-60825 compliant
 - 1490nm Continuous Mode Transmitter and 1310nm Burst Mode APD-TIA Receiver
 - Typical data rate 1.25 Gbps, Maximal reach 20km
 - Comply with China Telecom EPON equipment technical requirement V2.1
- 1000BASE-PX20+/++/+++

Product Applications

- GEAPON OLT For P2MP Application

General

The Z-Quick ZL5432099-ICSx transceiver with supports data rate of typical 1.25 Gbps for GEAPON OLT application up to 20km transmission distance, it's designed meeting with China Telecom EPON equipment technical requirement V2.1 1000BASE-PX20+/++/+++ specifications. SC receptacle is for optical interface.

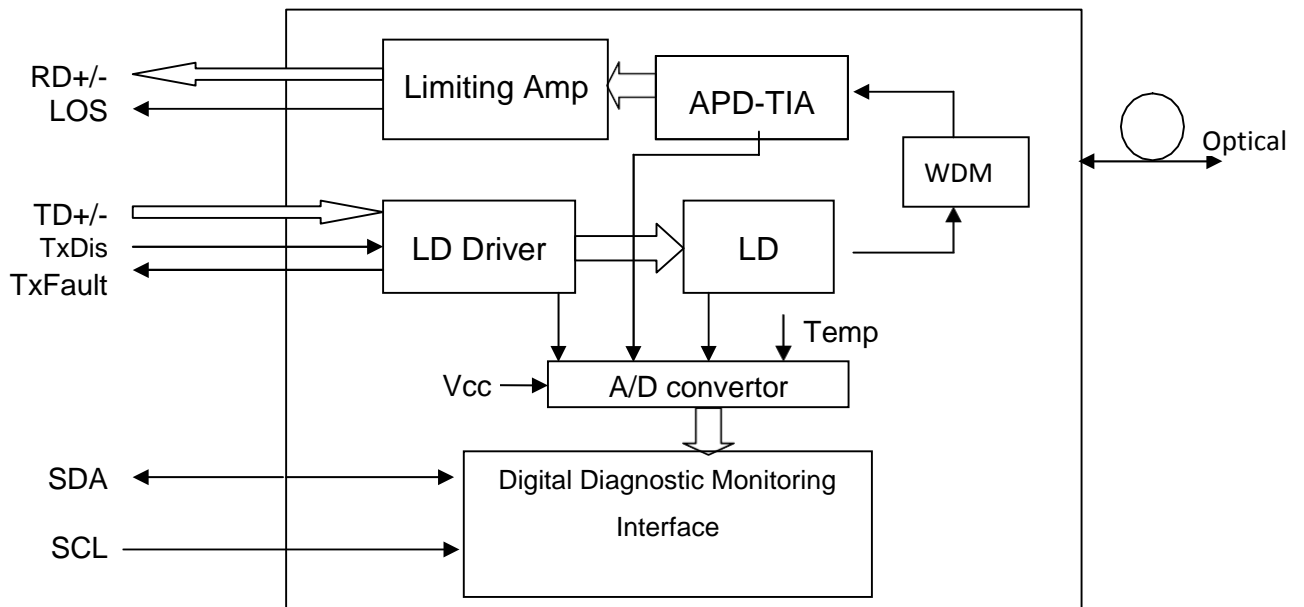

Fig 1 Transceiver Block Diagram

The module provides digital diagnostic information of its operating conditions and status, including transmitting power, laser bias, receiver input optical power, module temperature, and supply voltage. Calibration and alarm/warning threshold data are written and stored in internal memory (EEPROM). The memory map is compatible with SFF-8472, as shown in Fig. 2. The diagnostic data are raw A/D values and must be converted to real world units using calibration constants stored in EEPROM locations 56 – 95 in A2h.

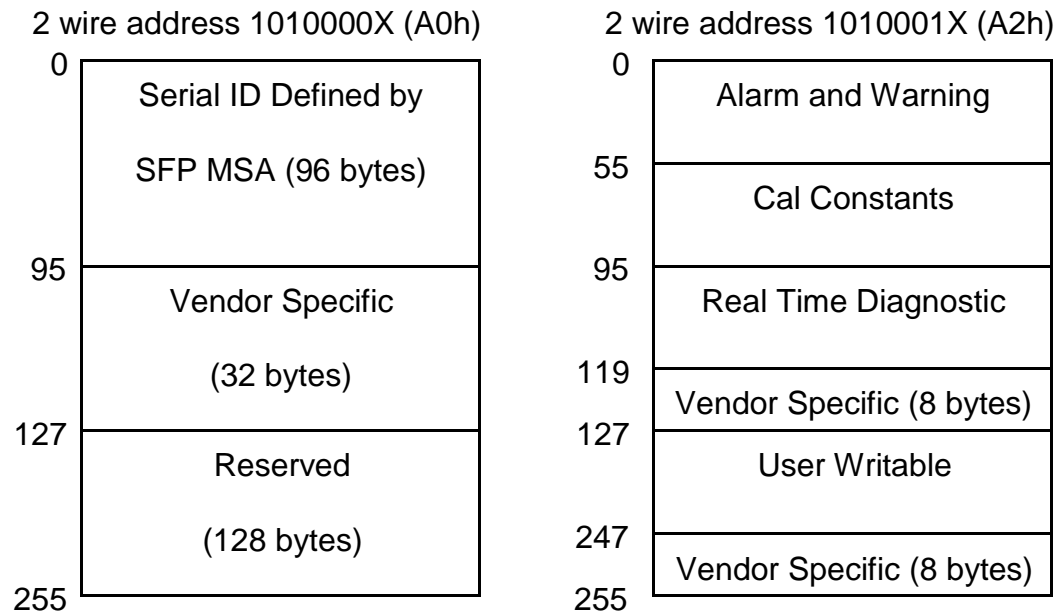

Fig 2 EEPROM Information

Performance Specifications

Absolute Maximum Ratings						
Parameter	Symbol	Min.	Max.	Unit	Note	
Storage Temperature	Tst	-40	+85	°C		
Operating Case Temperature	Tc	0	70	°C		
Input Voltage	-	GND	Vcc	V		
Power Supply Voltage	Vcc-Vee	-0.5	+3.6	V		
Recommended Operating Conditions						
Parameter	Symbol	Min.	Typical	Max.	Unit	Note
Power Supply Voltage	Vcc	3.135	3.3	3.465	V	
Operating Case	Tc	0	-	70	°C	

Temperature						
Data Rate	DR	-	1.25	-	Gbps	
Total Supply Current	-	-	-	400	mA	
Damage Threshold For Receiver	-	-	-	4	dBm	

Optical Specification						
Transmitter						
Parameter	Symbol	Min.	Typ.	Max.	Unit	Note
Optical Central Wavelength	λ	1480	1490	1500	nm	-
Spectral Width (-20dB)	$\Delta\lambda$	-	-	1	nm	-
Side Mode Suppression Ratio	SMSR	30	-	-	dB	-
Average Optical Output Power	Po	+2.5	+4	+7	dBm	ZL5432099 -ICS
		+3.5	+5	+7		ZL5432099 -ICSF
		+5	+7	+8		ZL5432099 -ICSP
Extinction Ratio	Er	9	-	-	dB	-
Rise/Fall Time	Tr/Tf	-	-	260	ps	-
Transmitter Total Jitter	Jp-p	-	-	344	ps	
Transmitter Reflectance	RFL	-	-	-12	dB	
Average Launched Power of Off Transmitter	Poff	-	-	-39	dBm	-
Differential Input Voltage	V _{IN-DIF}	300	-	1600	mV	-
Tx Disable Input Voltage-Low	V _{IL}	0	-	0.8	V	-
Tx Disable Input Voltage-High	V _{IH}	2.0	-	V _{CC}	V	-
Output Eye	Compliant with IEEE 802.3ah-2004					
Receiver						
Parameter	Symbol	Min.	Typ.	Max.	Unit	Note
Operate Wavelength	-	1260	1310	1360	nm	-
Sensitivity	Pr	-	-	-30	dBm	1
Saturation	Ps	-6	-	-	dBm	1
LOS assert Level	-	-45	-	-	dBm	-
LOS De-Assert Level	-	-	-	-30	dBm	-
LOS Hysteresis	-	0.5	-	5	dB	-
Receiver Optical Reflectance	-	-	-	-12	dB	-
Data Output Low	Vol	-2	-	-1.58	V	-

Data Output High	Voh	-1.1	-	-0.74	V	-
LOS Output Voltage-Low	VSD-L	0	-	0.8	V	-
LOS Output Voltage-High	VSD-H	2.0	-	Vcc	V	

Note:

1. Minimum Sensitivity and saturation levels for an 8B10B 2⁷-1 PRBS. BER≤10⁻¹², 1.25Gpbs, ER=9dB

EEPROM Information

EEPROM Serial ID Memory Contents (A0h)

Addr. (decimal)	Field Size (Bytes)	Name of Field	Content (Hex)	Content (Decimal)	Description
0	1	Identifier	03	3	SFP
1	1	Ext. Identifier	04	4	MOD4
2	1	Connector	01	1	SC
3-10	8	Transceiver	00 00 00 80 00 00 00 00	00 00 00 128 00 00 00 00	EPON
11	1	Encoding	01	1	8B10B
12	1	BR, nominal	0C	12	1.25Gpbs
13	1	Reserved	00	0	-
14	1	Length (9um)- km	14	20	20/km
15	1	Length (9um)	C8	200	20km
16	1	Length (50um)	00	0	-
17	1	Length (62.5um)	00	0	-
18	1	Length (copper)	00	0	-
19	1	Reserved	00	0	-
20-35	16	Vendor name	5A 2D 51 55 49 43 4B 20 20 20 20 20 20 20 20 20	90 45 81 85 73 67 75 32 32 32 32 32 32 32 32 32	'Z-QUICK' (ASCII)
36	1	Reserved	00	0	-
37-39	3	Vendor OUI	00 00 00	0 0 0	-
40-55	16	Vendor PN	5A 4C 35 34 33 32 30 39 39 2D 49 43 53 xx 20 20	90 76 53 52 51 50 48 57 57 45 73 67 83 xx 32 32	'ZL5432099-ICSx' (ASCII)
56-59	4	Vendor rev	30 30 30	48 48 48	"000" (ASCII)

			20	32	
60-61	2	Wavelength	05 D2	05 210	1490
62	1	Reserved	00	0	-
63	1	CC BASE	-	-	Check sum of bytes 0 - 62

64	1	Reserved	00	0	
65	1	Options	1A	26	
66	1	BR, max	00	0	-
67	1	BR, min	00	0	-
68-83	16	Vendor SN	-	-	ASCII
84-91	8	Vendor date	-	-	Year (2 bytes), Month (2 bytes), Day (2 bytes)
92	1	DDM Type	68	104	Internal Calibrated
93	1	Enhanced Option	B0	176	LOS, TX_FAULT and Alarm/warning flags implemented
94	1	SFF-8472 Compliance	03	3	SFF-8472 Rev 10.3
95	1	CC EXT	-	-	Check sum of bytes 64 - 94
96-255	160	Vendor spec			

Alarm and Warning Thresholds (Serial ID A2H)

Parameter(Unit)	C Temp (°C)	Voltage (V)	Bias (mA)	TX Power (dBm)			RX Power (dBm)
High Alarm	100	3.6	90	+7	+7	+8	-6
Low Alarm	-10	3	1	+2.5	+3.5	+5	-30
High Warning	95	3.5	70	+6	+6	+7.5	-7
Low Warning	0	3.1	2	+3	+4	+6	-29

Digital Diagnostic Monitor Accuracy

Parameter	Unit	Accuracy	Range	Calibration
Tx Optical Power	dB	±3	Po: -Pomin~Pomax dBm, Recommended operation conditions	External/Internal
Rx Optical Power	dB	±3	Pi: Ps~Pr dBm, Recommended operation conditions	External/Internal
Bias Current	%	±10	Id: 1-100mA, Recommended operating conditions	External/Internal
Power Supply Voltage	%	±3	Recommended operating conditions	External/Internal

Internal Temperature	°C	±3	Recommended operating conditions	External/Intern al
-------------------------	----	----	-------------------------------------	-----------------------

PIN Diagram

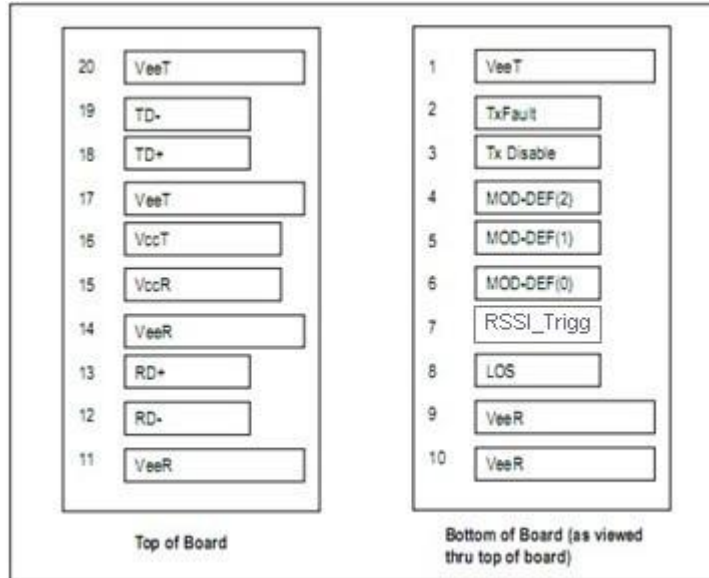

PIN Description

Pin No.	Name	Function	Plug Seq.	Notes
1	VeeT	Transmitter Ground	1	
2	Tx Fault	Transmitter Fault Indication	3	Note 1
3	Tx Disable	Transmitter Disable	3	Note 2
4	MOD-DEF2	Module Definition 2	3	Note 3
5	MOD-DEF1	Module Definition 1	3	Note 3
6	MOD-DEF0	Module Definition 0	3	Note 3
7	RSSI_Trigg	Receiver Signal Strength Indication	3	
8	LOS	Los Of Signal	3	Note 4
9	VeeR	Receiver Ground	1	Note 5
10	VeeR	Receiver Ground	1	Note 5
11	VeeR	Receiver Ground	1	Note 5
12	RD-	Inv. Receiver Data Out	3	Note 6
13	RD+	Receiver Data Out	3	Note 6
14	VeeR	Receiver Ground	1	Note 5
15	VccR	Receiver Power Supply	2	Note 7, 3.3V± 5%
16	VccT	Transmitter Power Supply	2	Note 7, 3.3V± 5%
17	VeeT	Transmitter Ground	1	Note 5
18	TD+	Transmitter Data In	3	Note 8
19	TD-	Inv. Transmitter Data In	3	Note 8
20	VeeT	Transmitter Ground	1	Note 5

Notes:

1. TX Fault is an open collector/drain output, which should be pulled up with a 4.7K–10K Ω resistor on the host board. Pull up voltage between 2.0V and VccT, R+0.3V. When high, output indicates a laser fault of some kind. Low indicates normal operation. In the low state, the output will be pulled to < 0.8V.
2. TX disable is an input that is used to shut down the transmitter optical output. It is pulled up within the module with a 4.7–10 K Ω resistor. Its states are:

Low (0 – 0.8V):	Transmitter on
(>0.8, < 2.0V):	Undefined
High (2.0 – 3.465V):	Transmitter Disabled
Open:	Transmitter Disabled
3. Mod-Def 0,1,2. These are the module definition pins. They should be pulled up with a 4.7K – 10K Ω resistor on the host board. The pull-up voltage shall be VccT or VccR.
Mod-Def 0 is grounded by the module to indicate that the module is present
Mod-Def 1 is the clock line of two wire serial interface for serial ID
Mod-Def 2 is the data line of two wire serial interface for serial ID
4. LOS (Loss of Signal) is an open collector/drain output, which should be pulled up with a 4.7K – 10K Ω resistor. Pull up voltage between 2.0V and VccT, R+0.3V. When high, this output indicates the received optical power is below the worst-case receiver sensitivity (as defined by the standard in use). Low indicates normal operation. In the low state, the output will be pulled to < 0.8V.
5. VeeR and VeeT may be internally connected within the SFP module.
6. RD-/+ : These are the differential receiver outputs. They are DC coupled 100 Ω differential lines which should be terminated with 100 Ω (differential) at the user SERDES.
7. VccR and VccT are the receiver and transmitter power supplies. They are defined as 3.3V \pm 5% at the SFP connector pin. Maximum supply current is 450mA. Recommended host board power supply filtering is shown below. Inductors with DC resistance of less than 1 Ω should be used in order to maintain the required voltage at the SFP input pin with 3.3V supply voltage. When the recommended supply filtering network is used, hot plugging of the SFP transceiver module will result in an inrush current of no more than 30 mA greater than the steady state value. VccR and VccT may be internally connected within the SFP transceiver module.
8. TD-/+ : These are the differential transmitter inputs. They are AC-coupled, differential lines with 100 Ω differential termination inside the module. The AC coupling is done inside the module and is thus not required on the host board.

Package Diagram

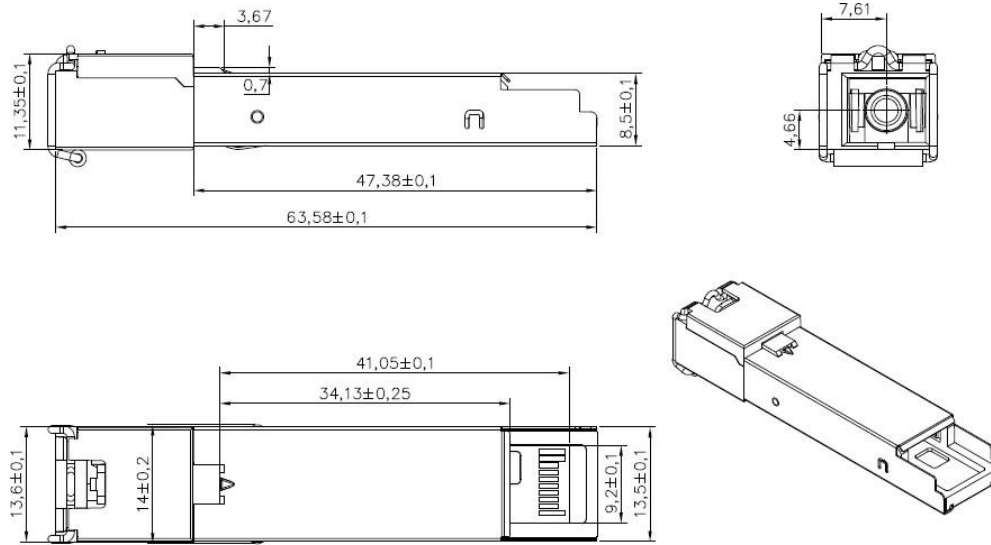

Recommended Circuit

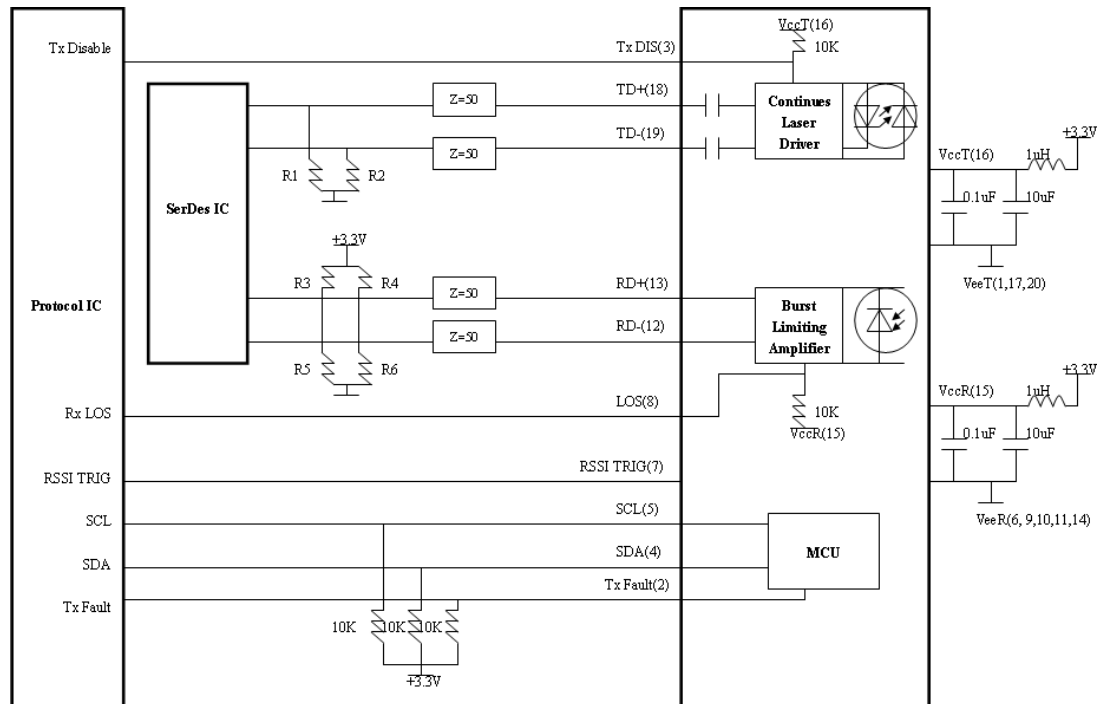

Note:

Tx: AC coupled internally.

$$R1=R2=150\Omega.$$

Rx: LVPECL output, DC coupled internally.

Input stage in SerDes IC with internal bias to $V_{cc}-1.3V$

$$R3=R4=R5=R6=N.C$$

Input stage in SerDes IC without internal bias to $V_{cc}-1.3V$

$$R3=R4=130\Omega, R5=R6=82\Omega.$$

Timing Parameter Definition

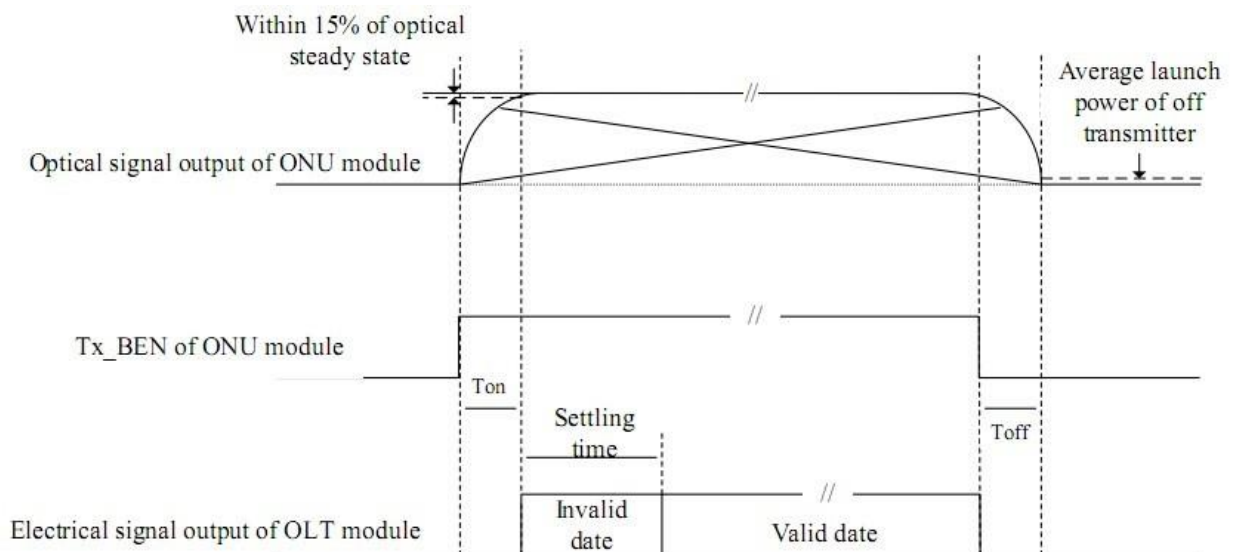

Figure1 Time parameter definition in EPON system

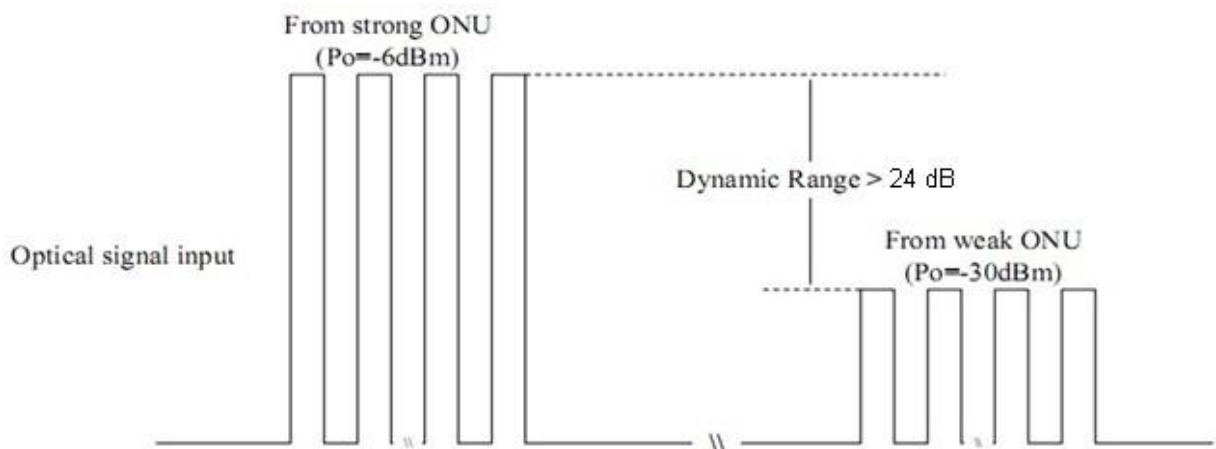
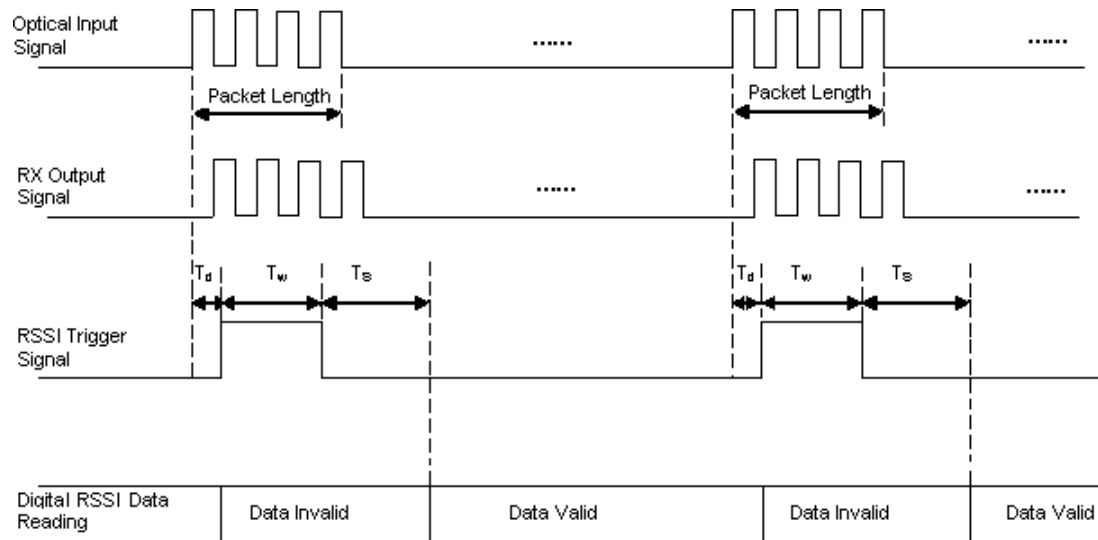

Figure2 Burst_mode Receiver Dynamic range in EPON system

Timing Of Digital RSSI



PARAMETER	SYMBOL	MIN	TYP	MAX	UNITS
Packet Length	-	600	-	-	ns
Trigger delay	T_d	100	-	-	ns
RSSI Trigger and Sample Time	T_w	500	-	-	ns
Internal delay	T_s	500	-	-	us

Change History

Version	Change Description	Issued By	Checked By	Approved By	Release Date
A	Initial release	Haiping Li	Allan.Ding	LK.Wang	2016-01-18
B	Add PN of P0 +5 / +7	Haiping Li	Allan.Ding	LK.Wang	2016-01-28
C	Update receiver wavelength, Package.	Yebinghua	Peng Zhen	LK.Wang	2020-03-31