



UC200-2S20 Universal Gateway

User Manual V1.0



Shenzhen Dinstar Co., Ltd.

Address: 9th Floor, Guoxing Building, Changxing Road, Nanshan District, Shenzhen, China

Postal Code: 518052

Telephone: +86 755 61919966

Fax: +86 755 2645 6659

Emails: sales@dinstar.com, support@dinstar.com

Website: www.dinstar.com

Preface

Welcome

Thanks for choosing the **UC200-2S2O Universal Gateway**! We hope you will make full use of this rich-feature gateway. Contact us if you need any technical support: 86-755-26456110/112.

About This Manual

This manual provides information about the introduction of the gateway, and about how to install, configure or use the gateway. Please read this document carefully before installing the gateway.

Intended Audience

This manual is aimed primarily at the following people:

- Users
- Engineers who install, configure and maintain the gateway.

Revision Record

Document Name	Document Version	Firmware Version
UC200-2S2O Universal Gateway User Manual V1.0	V1.0 (2018/09/018)	1.54.1.5

Conventions

Gateway or device mentioned in this document refers to the UC200-2S2O gateway. Those words in blue are the contents that users need to pay attention to.

Contents

1 Product Introduction	1
1.1 Overview	1
1.2 Application Scenario	1
1.3 Product Appearance	2
1.4 Description of Indicators	2
1.5 Features & Functions.....	3
1.5.1 Key Features	3
1.5.2 Physical Interfaces	3
1.5.3 Voice Capabilities	3
1.5.4 FXS.....	4
1.5.5 FXO	4
1.5.6 Software Features	4
1.5.7 Environmental	5
1.5.8 Maintenance	5
2 Quick Installation.....	6
2.1 Installation Attentions	6
2.2 Installation Steps	6
2.3 Network Connection.....	6
2.3.1 Network Connection Diagram under Route Mode.....	6
2.3.2 Network Connection Diagram under Bridge Mode	7
2.4 Connect Gateway to Network	8
2.4.1 Connect Gateway to Network via Network Port.....	8
2.4.2 Log In Web Interface	8
3 Basic Operation	9
3.1 Methods to Number Dialing	9
3.2 Call Holding	9
3.3 Call Waiting	9
3.4 Call Transfer.....	9
3.4.1 Blind Transfer.....	9
3.4.2 Attended Transfer	10
3.5 Function of Flash-hook.....	11

3.6 Description of Feature Code	11
3.7 Send or Receive Fax	12
3.7.1 Fax Mode Supported	12
3.7.2 Explanation of T.38 and Pass-through.....	12
3.8 Function of RST Button.....	13
3.9 Query IP Address and Restore Default Setting	14
4 Configuration Wizard.....	15
4.1 Configuration Wizard	15
4.1.1 UC200 Regarded as Terminal and Registered to SIP Server	15
4.1.2 Other SIP Clients registered to UC200.....	16
4.1.3 UC200 Connected to PBX through Trunking	16
5 Configurations on Web Interface	17
5.1 Introduction to Web Interface	17
5.2 Status.....	18
5.2.1 Overview	18
5.2.2 SIP	19
5.2.3 PSTN.....	20
5.2.4 DHCP Client List.....	20
5.2.5 Current Call.....	21
5.2.6 CDRs.....	21
5.2.7 Service	22
5.2.8 About.....	22
5.3 System.....	22
5.3.1 Setting	22
5.3.2 User Manager	24
5.3.3 Provision	25
5.3.4 Operation Log	27
5.3.5 Service Log	27
5.3.6 Config Changes Log	27
5.3.7 Backup/Restore/Upgrade	28
5.3.8 Voice	29
5.3.9 Command Line	30
5.3.10 Diagnostics.....	30
5.3.11 API	31
5.3.12 Reboot.....	31
5.4 Network	31
5.4.1 Setting	31

5.4.2 Access Control.....	34
5.4.3 Firewall	35
5.4.4 DHCP Server.....	37
5.4.5 Port Mapping.....	38
5.4.6 DMZ Setting.....	39
5.4.7 Diagnostics	39
5.4.8 Static Route	41
5.4.9 UPnP Client.....	42
5.4.10 Hosts	43
5.5 Profile	44
5.5.1 SIP	44
5.5.2 FXS/FXO	46
5.5.3 Codec	52
5.5.4 Number	52
5.5.5 Time	55
5.5.6 Manipulation	55
5.5.7 Dialplan.....	56
5.6 Extension	58
5.6.1 SIP	58
5.6.2 FXS.....	61
5.6.3 Ring Group.....	63
5.7 Trunk.....	64
5.7.1 SIP	64
5.7.2 FXO	66
5.8 Call Control.....	70
5.8.1 Setting	70
5.8.2 Route Group.....	71
5.8.3 Route.....	72
5.8.4 Feature Code	74
5.8.5 IVR	75
5.8.6 SMS Route	77
5.8.7 Diagnostics	79
6 Glossary.....	80

1 Product Introduction

1.1 Overview

UC200-2S20 is an IP telephony system providing superior VoIP service. It can help small and medium-sized enterprises establish a convenient and high-efficient communication way.

The gateway provides 2 FXS ports and 2 FXO ports basically to connect with telephony networks (such as PSTN and VoIP), and meanwhile it can be extended by the Session Initiation Protocol (SIP) to interwork with IPPBX, softswitch and SIP-based network platforms.

UC200-2S20 can be widely used in small and medium-sized call centers and enterprise branches to improve work efficiency and save communication cost.

1.2 Application Scenario

The application scenario of UC200-2S20 universal gateway is shown as follows:

Figure 1-1 Application Scenario of UC200-2S20

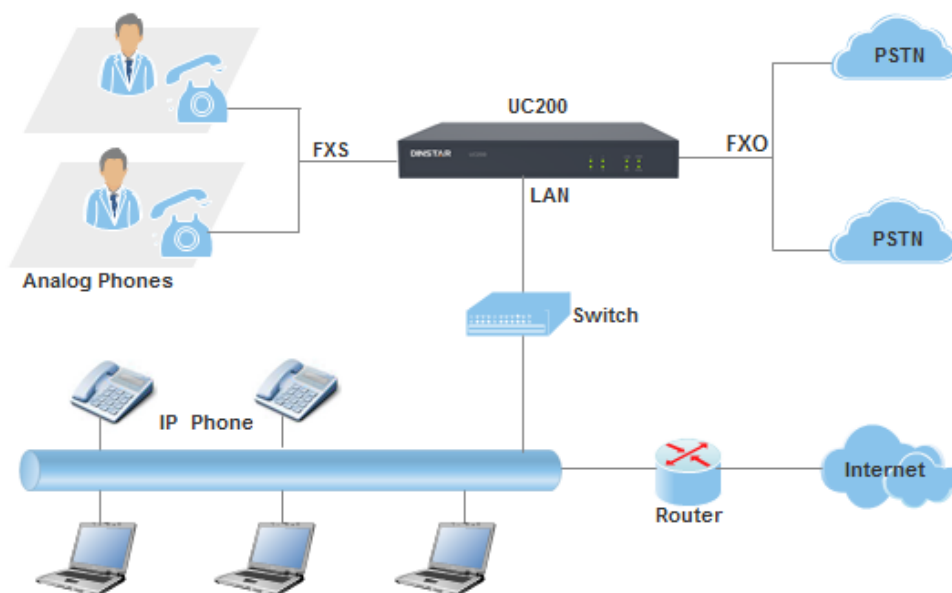

1.3 Product Appearance

Front View:

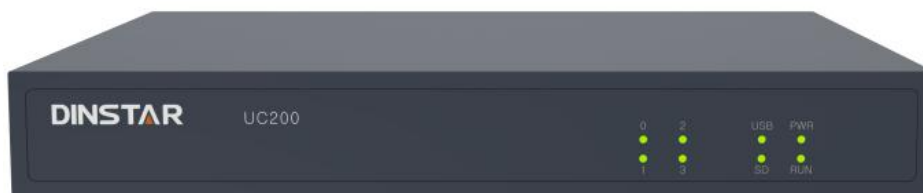

Back View:



1.4 Description of Indicators

Indicator	Definition	Status	Description
PWR	Power Indicator	Off	There is no power supply or power supply is abnormal.
		On	The UC200 device is powered on.
RUN	Running Indicator	Slow Flashing	The device is initialized successfully and is running normally
		On	The device is being initialized.
		Off	The device is not running normally.
FXS	FXS In-use Indicator	Flashing (every 2s)	The FXS port is in idle status.
		On	The FXS port is currently occupied by a call.
		Off	The FXS port is faulty
FXO	FXO In-use Indicator	Fast Flashing (every 2s)	The FXO port is connected to PSTN and is in idle status.
		Slow Flashing (every 4s)	The FXO port is not connected to PSTN, but is in normal status.
		On	The FXO port is currently occupied by a call
		Off	The FXO port is faulty.

WAN/LAN	Network Connection Indicator	Off	Network does not work or network cable is not connected.
		Flashing (every 1s)	The device is successfully connected to network

1.5 Features & Functions

1.5.1 Key Features

- FXS/FXO port on a single gateway
- Send/receive calls from PSTN/PLMN via FXO
- Flexible dial plan and routing strategies based on time, number and source IP etc.
- IVR Customization
- Support high-speed NAT forwarding
- Built-in SIP server, support up to 256 SIP extensions and 15 concurrent calls
- User-friendly web interface, multiple management ways

1.5.2 Physical Interfaces

- 2 FXS Ports
- 2 FXO Ports
- 1 USB Interface
- 1 SD Card Slot
- 1 WAN Port & 1 LAN Ports (10/100 Base-T RJ45)
- 1 Console Port
- 2 FXS LED Indicators and 2 FXO LED Indicators

1.5.3 Voice Capabilities

- VoIP Protocols: SIP over UDP/TCP/TLS, SDP, RTP/SRTP
- Codecs: G.711a/μ law, G.723.1, G.729A/B
- Silence Suppression
- Comfort Noise Generator(CNG)
- Voice Activity Detection(VAD)
- Echo Cancellation: G.168 with up to 128ms
- Dynamic Jitter Buffer
- Adjustable Gain Control
- Automatic Gain Control (AGC)
- Call Progress Tones: Dial Tone, Ring Back Tone, Busy Tone

- FAX: T.38 and Pass-through
- NAT Traversal: STUN/UPnP
- DTMF: RFC2833/Signal/Inband

1.5.4 FXS

- FXS Connector: RJ11
- Caller ID: Bellcore Type 1&2, ETSI, BT, NTT and DTMF
- Answer and Disconnect Signaling: Answer, Disconnect, Busy Tone
- Polarity Reversal
- Hook Flash

1.5.5 FXO

- FXO Connector: RJ11
- Caller ID: FSK and DTMF
- Polarity Reversal
- Answer Delay
- Detection of Busy Tone
- Detection of No Current
- Auto Match of FXO Impedance

1.5.6 Software Features

- Call Forward (Unconditional/No Answer/Busy)
- Call Waiting
- Call Holding
- Call Transfer (Blind & Attended)
- Hotline
- Do-not-disturb
- 3-way Conference
- Ring Groups (Intra-group Pick-up)
- Call Queue
- Caller/Called Number Manipulation
- Routing Based on Caller/Called Number Prefix
- Routing Based on Source Trunks
- Dial Rules
- Failover Routing
- IVR Customization

- Voicemail
- Auto Attendant Function
- CDRs

1.5.7 Environmental

- Power Supply: 12VDC, 2A
- Power Consumption: 18W
- Operating Temperature: 0 °C ~ 45 °C
Storage Temperature: -20 °C~80 °C
- Humidity: 10%-90% (Non-Condensing)
- Dimensions: 260×180×35mm (W/D/H)
- Weight: 1.0kg

1.5.8 Maintenance

- Web GUI for Configuration
- Telnet Management
- Configuration Restore & Backup
- Multiple Languages Supported
- Firmware Upgrade: support HTTP/TFTP/FTP
- Auto Provision
- CDR Query and Export
- Syslog Query and Export
- Network Tools: Ping, Traceroute
- Network Capture

2 Quick Installation

2.1 Installation Attentions

To avoid unexpected accident or device damage, please read the following instructions before installing the UC200-2S2O gateway.

- The adapter of the gateway accepts DC input voltage of 12V 2A. Please ensure stable and safe power supply;
- To reduce the interference to telephone calls, please separate power cables from telephone lines.
- To guarantee stable running of the gateway, please make sure that there is enough network bandwidth.
- For better heat dissipation, please place the gateway on a flat surface and do not pile up

2.2 Installation Steps

- Connect the power adapter to the power jack;
- Connect telephone line to the FXS port and connect PSTN line to the FXO port;
- Connect network cable to the LAN port(s) and WAN port (please refer to 2.3 Network Connection);

2.3 Network Connection

UC200-2S2O works in two network modes: route mode and bridge mode. When it is under the route mode, the IP address of WAN port must be different from the IP address of LAN port. But when it is under the bridge mode, the IP address of WAN port and that of LAN port are the same.

2.3.1 Network Connection Diagram under Route Mode

Under the route mode, the default IP address of WAN port is a DHCP IP address, while the default IP address of the LAN port is a static IP address, namely 192.168.11.1.

Figure 2-1 Network Connection Diagram under Route Mode

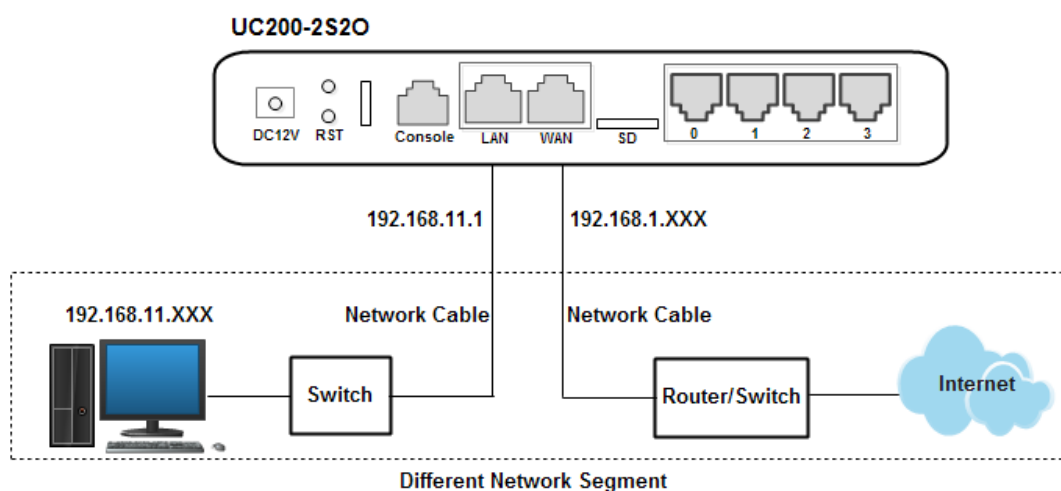

Note: The IP address of LAN port of the gateway and the IP address of PC must be at the same network segment, while that of WAN port is at a different network segment.

2.3.2 Network Connection Diagram under Bridge Mode

Under the Bridge mode, the IP address of WAN port is the same with that of LAN port. Generally, when the gateway works under the bridge mode, the IP address of the gateway has been modified. In the following diagram, it is assumed that the IP address has been modified into 172.16.80.1.

Figure 2-2 Network Connection Diagram under Bridge Mode

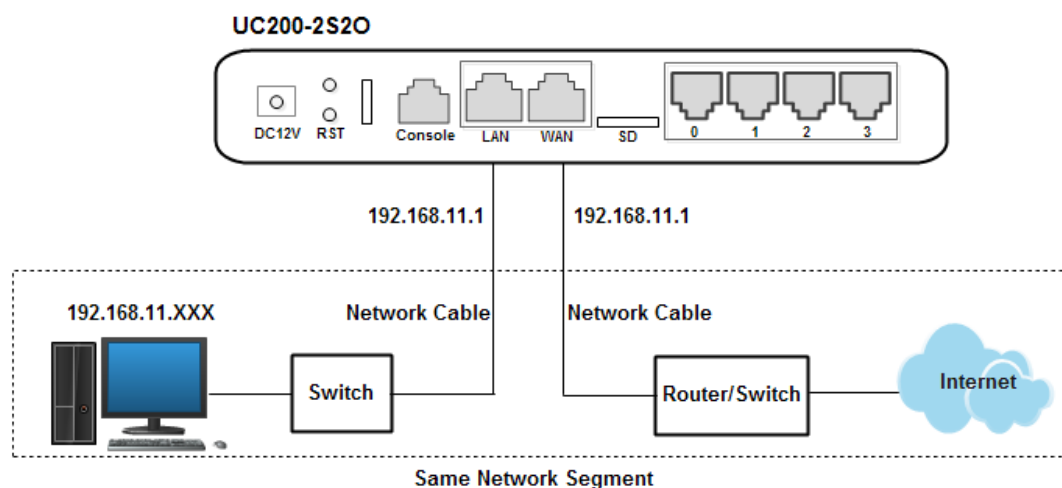

Note: The IP address of PC and that of WAN port of the UC200-2S20 gateway are at the same network segment.

2.4 Connect Gateway to Network

2.4.1 Connect Gateway to Network via Network Port

Please connect the UC200-2S2O gateway to network according to the network diagrams in Section 2.3 Network Connection. Then connect a telephone to the FXS port. Dial *158# to query the IP address of LAN port. Modify the IP address of PC to make it at the same network segment of LAN port of the gateway.

2.4.2 Log In Web Interface

Open a web browser and enter the IP address of LAN port (the default IP is 192.168.11.1). Then the login GUI will be displayed.

You also can enter the IP address of WAN port, but it's required to modify the IP address of PC to make it at the same network segment with that of WAN port.

It is suggested that you should modify the username and password for security consideration.

Figure 2-3 Login GUI of UC200-2S2O

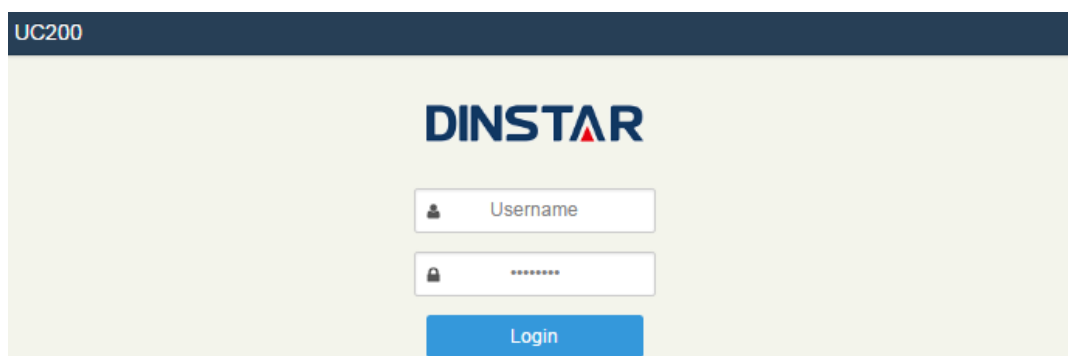

The default username and password are admin and admin@123# respectively. Click **Login** to enter into the web interface.

Under some circumstances, login of the Web will be limited:

- For three consecutive login failures, you need to slide to validate your user account;
- Failing to log in the Web for ten times consecutively, the IP address of the UC200 device will be put into the blacklist, and you need to reset a new IP address for the device;
- Successful login or device restart will wipe out login failure records.

3 Basic Operation

3.1 Methods to Number Dialing

There are two methods to dial telephone number or extension number:

- Dial the called number and wait for 4 seconds for dialing timeout, or dial the called number directly (the system will judge whether the dialing is completed according to Digitmap and Regular Expression dialplans).
- Dial the called number and press #.

3.2 Call Holding

If a calling party places a call to a called party which is otherwise engaged, and the called party has the call holding feature enabled, the called party is able to switch to the new incoming call while keeping the current call holding on by pressing the flash button or the flash hook.

When the called party presses the flash button or the flash hook once again, he or she will switch back to the first call.

3.3 Call Waiting

If a calling party places a call to a called party which is otherwise engaged, and the called party has the call waiting feature enabled, the calling party will hear a IVR voice 'Please hold on, the subscriber you dialed is busy' and the called party will hear three beeps.

By pressing the flash button or the flash hook, the called party is able to switch between the new incoming call and the current call.

3.4 Call Transfer

3.4.1 Blind Transfer

Blind transfer is a call transfer in which the transferring party connects the call to a third party without notifying the third party.

Example: A gives a call to B and B wants to blindly transfer the call to C. Operation instructions are as follows:

1. A dials the extension number of B;
2. The extension of B rings, and B picks up the phone. Then A and B go into conversation;
3. B presses *1 to trigger blind transfer (at the same time, A can hear the waiting tone). Then B dials the extension number of C (end up with # or wait for 4 seconds);
4. The extension of C rings, B hangs up the phone and C picks up the phone. Then C and A goes into conversation.

Note:

- On the 'Call Control → Feature Code' page, feature code service should be 'On'.
- If B hears continuous busy tones after he dials the extension number of C, it means the call has timed out.

3.4.2 Attended Transfer

Attended transfer is a call transfer in which the transferring party connects the call to a third party after he confirms that the third party agrees to answer the call.

Example: A gives a call to B and B wants to attended transfer the call to C. Operation instructions are as follows:

1. A dials the extension number of B;
2. The extension of B rings, and B picks up the phone. Then A and B go into conversation;
3. B presses *2 to trigger attended transfer (at the same time, A can hear a waiting tone). Then B dials the extension number of C;
4. Then one of the following situations will happen:
 - a. If the extension of C cannot be reached because the dialing/call has timed out, C rejects the call or C is busy, B will automatically switch to the conversation with A.
 - b. The extension of C rings (at the same time, B can hear a ringback tone). If B hangs up the phone at this moment, A will continue to hear the waiting tone. Then if A also hangs up the phone, the extension of C will continue to ring. If C picks up the phone at this moment, the call will end directly.
 - c. The extension of C rings and then C picks up the phone. C and B go into conversation, and A will continue to hear a waiting tone. If it's B that hangs up the phone at this moment, C and A go into conversation. If it's C that hangs up the phone, B and A go into conversation.

3.5 Function of Flash-hook

Assume A and B are in a call conversation:

If A presses the flash hook, and then dial the number of C, A and C go into conversation and meanwhile the call between A and B is kept holding.

Then, if A presses the flash hook and dial 1, the conversation will switch back to A and B; if A presses the flash hook and dial 2, the conversation will switch to A and C; if A presses the flash hook and dial 3, the conversation will switch to A, B and C (three parties conversation).

3.6 Description of Feature Code

UC200-2S20 provides convenient telephone functions. Connect a telephone to the FXS port and dial a specific feature code, and you can query corresponding information.

Code	Corresponding Function
*159	Dial *159 to inquiry WAN IP
*158	Dial *158 to inquiry LAN IP
*114	Dial *114 to inquiry phone number
157	Dial *157*0 to set route mode; dial *157*1 to set bride mode
150	Dial *150*1 to set IP address as static IP address; dial *150*2 to set IP address as DHCP IP address
152	Dial *152* to set IPv4 address, for example: Dial *152*192*168*1*10# to set IPv4 address as 192.168.1.10
156	Dial *156* to set IPv4 gateway, for example: Dial *156*192*168*1*1# to set IPv4 gateway as 192.168.1.1
153	Dial *153* to set IPv4 netmask, for example: Dial *153*255*255*0*0*# to set IPv4 netmask as 255.255.0.0
*111	Dial *111 to restart the UC200 device
*51	Dial *51 to enable the call waiting service
*50	Dial *50 to disable the call waiting service
*1	Dial *1 to trigger blind transfer, for example: Dial *18000, and you can blind transfer to the extension number 8000
*2	Dial *2 to trigger attended transfer, for example: Dial *28000#, and you can attended transfer to the extension number 8000

72	Enable unconditional call forwarding service. Example: Dial *72*8000, and calls will be unconditionally forwarded to extension number 8000
*73	Disable unconditional call forwarding service
90	Enable the 'call forwarding on busy' service. Example: Dial *90*8000, and calls will be forwarded to extension number 8000 when the called number is busy
*91	Disable the 'call forwarding on busy' service
92	Enable the 'call forwarding on no reply' service. Example: Dial *92*8000, and calls will be forwarded to extension number 8000 when there is no reply from the called number
*93	Disable the 'call forwarding on no reply' service
*78	Enable the 'No Disturbing' service
*79	Disable the 'No Disturbing' service
**	Pick up the ringing extension which is in the same ringgroup. Example: Dial**8000, and you can take the incoming call of extension number 8000
160	Dial *160*1# to allow HTTP WAN access, Dial *160*0# to deny HTTP WAN access

Note:

A voice prompt indicating successful configuration will be given after each configuration procedure. Please do not hang up until hearing this voice prompt.

3.7 Send or Receive Fax

3.7.1 Fax Mode Supported

- T.38 (IP-based)
- T.30 (Pass-Through)

3.7.2 Explanation of T.38 and Pass-through

T.38 is an ITU recommendation for allowing transmission of fax over IP networks in real time. Under the T.38 mode, analog fax signal is converted into digital signal and fax signal tone is restored according to the signal of peer device. Under the T.38 mode, fax traffic is carried in T.38 packages.

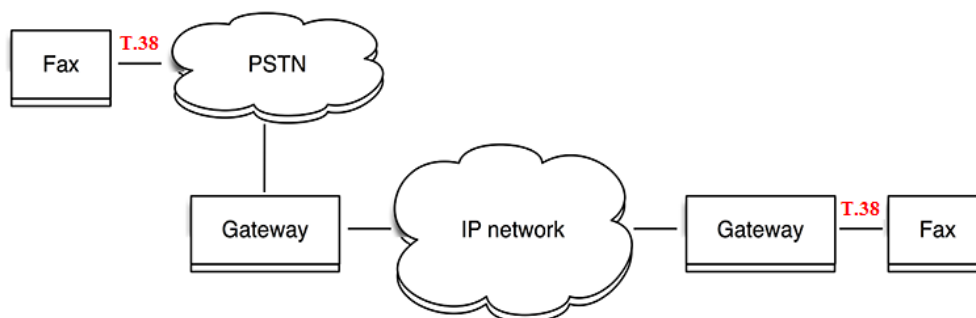

Pass-through (T.30): Under the pass-through mode, fax signal is not converted and fax traffic is carried in RTP packets. It uses the G.711 A or G.711U codec in order to reduce the damage to fax signal.

3.8 Function of RST Button

Press the RST button for different time length, and the UC200-2S2O device will execute different function:

1. On the condition that the device is running normally, press the RST1 or RST2 button for 0 to 3 seconds, the system will not execute any function.
2. On the condition that the device is running normally, press the RST1 button for 3 seconds to 6 seconds, the IP address, username and password of the device will be restored to factory defaults, and meanwhile the access ports of Http, Https, Telnet and SSH are restored to the default settings.

Figure 3-1 Default settings of Http, Https, Telnet and SSH

Network / Access Control

Web Server

HTTP Port: 80

Allow WAN access:

HTTPS Port: 443

Allow WAN access:

Telnet

Enable:

Port: 23

Allow WAN access:

SSH

Port: 22

Allow WAN access:

Buttons: Cancel Save Reset

3. On the condition that the device is running normally, press the RST2 button for more than 6 seconds, and all configurations are restored to the default settings.

3.9 Query IP Address and Restore Default Setting

After connecting a telephone to the FXS port, you can dial *158 to query the IP address of LAN port and dial *159 to query the IP address of WAN port.

If you want to restore UC200-2S20 to default settings, you can press the **RST** button for more than 6 seconds or you can configure it on the Web interface.

On the Web interface, click **System** → **Backup/Restore/Upgrade** and then select the parts (system, network or service) that need to be restored to default settings. Click **Reset** and then restart the device, and the selected parts will be restored to default settings.

Figure 3-2 Reset to Defaults

The screenshot displays the 'System / Backup/Restore/Upgrade' web interface. It features two tabs: 'Upgrade' and 'Backup/Restore', with 'Backup/Restore' currently selected. The interface is organized into three rows of options:

- Choose backup files and download:** Includes checkboxes for 'System' (checked), 'Network' (checked), and 'Service' (checked), followed by a blue 'Download' button.
- Reset to defaults:** Includes checkboxes for 'System' (checked), 'Network' (unchecked), and 'Service' (checked), followed by a blue 'Reset' button.
- Restore from the backup:** Includes a 'Choose File' button and a text field containing 'No file chosen', followed by a grey 'Restore' button.

4 Configuration Wizard

4.1 Configuration Wizard

The following are the common ways to configure the UC200-2S2O gateway.

4.1.1 UC200 Regarded as Terminal and Registered to SIP Server

1. UC200-2S2O Registered to SIP Server

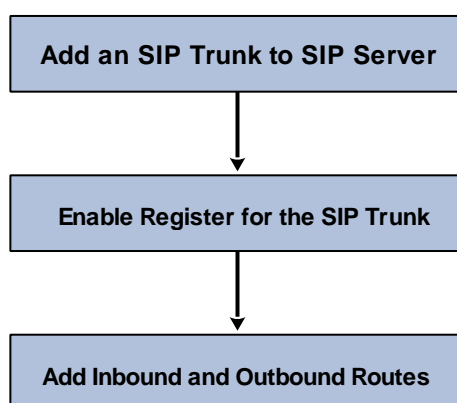

2. FXS/FXO Port Registered to SIP Server

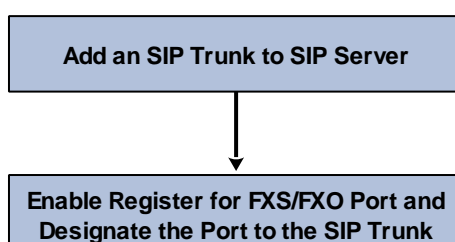

Note: Although 'Register' has been enabled for FXS/FXO port, calls through FXS/FXO port will take inbound and outbound routes as first priority. For outgoing calls, if outbound route cannot be matched, then the registered SIP trunk will be selected. For incoming calls, if inbound route cannot be matched, then the registered FXS/FXO port will be selected.

Generally, local extension number is taken as first priority for call routing selection, followed by DID, route and then registered port.

4.1.2 Other SIP Clients registered to UC200

Under this mode, UC200-2S2O is regarded as an SIP Server. Create an extension account first on the **Extension →SIP** interface, and configure listening port on the **Profile → SIP** interface. Then, configure the IP address, extension account and listening port of UC200-2S2O on SIP client.

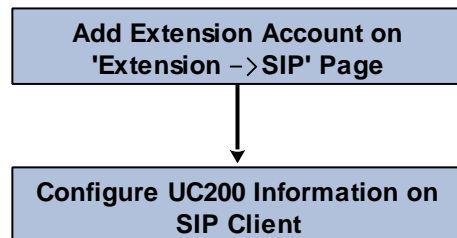

4.1.3 UC200 Connected to PBX through Trunking

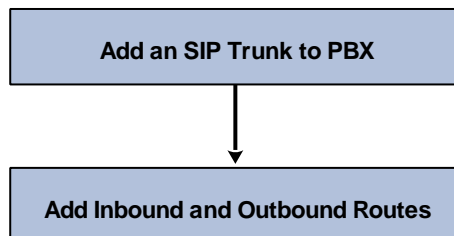

5 Configurations on Web Interface

5.1 Introduction to Web Interface

Modify the IP address of PC to make it at the same network segment with that of LAN port of the UC200-2S2O gateway (the default IP of LAN port is 192.168.11.1).

Open a web browser on the PC and then enter the IP address of LAN port. Click **Login**, and the login GUI is displayed. Both the default username and password are admin.

The displayed login GUI is shown as follows:

Figure 5-1 Introduction to login GUI

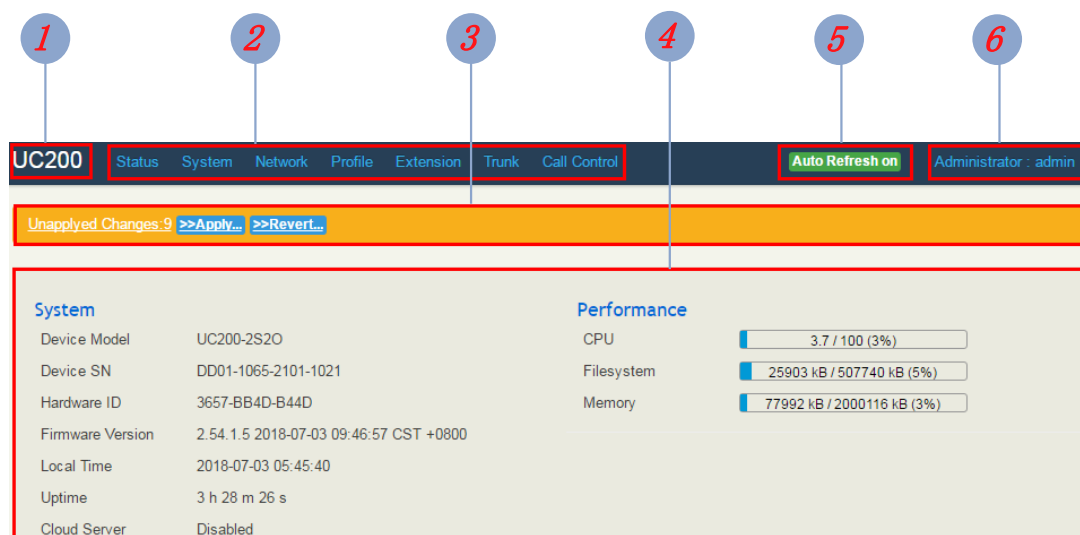

Table 5-1 Introduction of Web Interface

Index	Item	Description
1	UC200	The name of the gateway; it can be edited on the System → Setting interface
2	Menu Bar	The menu bar of UC200-2S2O
3	Unsaved Changes	All changes to the configuration of the gateway need to be saved. Click Apply to enter into the page to save the changes; click Revert to return to original configuration.
4	Detailed Interface	The detailed configuration interface or display interface
5	Auto Refresh	The button can be enabled or disabled. If it is enabled, the

		information on the Status → Overview/SIP/PSTN/Current Call interfaces will be refreshed automatically
6	User Group	It can display the user group and its name. The “Logout” sign will pop up when the mouse moves over here, and you can drop the web from here.

5.2 Status

The ‘Status’ menu mainly displays all kinds of status information. It includes the following sub-menus: Overview, SIP, PSTN, DHCP Client List, Current Call, CDRs, Service and About.

5.2.1 Overview

Log in the Web interface of UC200-2S2O, click **Status → Overview**, and the following interface will be displayed. On the interface, device model, firmware version as well as information about performance, WAN network, LAN network and DHCP server are shown.

Figure 5-2 Overview

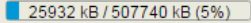
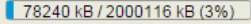
System Device Model UC200-2S2O Device SN DD01-1065-2101-1021 Hardware ID 3657-BB4D-B44D Firmware Version 2.54.1.5 2018-07-03 09:46:57 CST +0800 Local Time 2018-07-04 05:54:50 Uptime 1 d 3 h 37 m 36 s Cloud Server Disabled		Performance CPU  3.7 / 100 (3%) Filesystem  25932 kB / 507740 kB (5%) Memory  78240 kB / 2000116 kB (3%)	
WAN Network MAC Address F8-A2-4D-62-52-12 Type DHCP DHCP Server 172.18.1.2 IP Address 172.18.0.147 Netmask 255.255.0.0 Gateway 172.18.1.2 DNS 8.8.8.8 114.114.114.114 RX / TX (Per Second) 1.61 KB (15 Pkts.) / 524 Bytes (2 Pkts.) RX / TX (Total) 242.15 MB (2116212 Pkts.) / 25.93 MB (110757 Pkts.)		LAN Network MAC Address F8-A2-4D-62-52-11 Type Static IP Address 192.168.11.1 Netmask 255.255.255.0 RX / TX (Per Second) 0 Bytes (0 Pkts.) / 0 Bytes (0 Pkts.) RX / TX (Total) 0.00 B (0 Pkts.) / 111.62 KB (1592 Pkts.)	
		DHCP Server Status Enabled Start Address 192.168.11.99 End Address 192.168.11.198 Gateway - Expires 12 Hours DNS -	

5.2.2 SIP

Click **Status** → **SIP**, information of SIP extension, SIP trunk and SIP profile is shown.

Figure 5-3 Status of SIP Profile, SIP Trunk and SIP Extension

SIP Extension								SIP Trunk		SIP Profile	
Index	Name	Extension	Register Source	Status	Expires	Agent	Profile				
1	1000	1000		Unregistered			2-< wan_default >				
2	1001	1001		Unregistered			2-< wan_default >				
3	1002	1002		Unregistered			2-< wan_default >				
4	1003	1003		Unregistered			2-< wan_default >				
5	1004	1004	172.18.100.18:5060	Registered(...)	3443	Linphone/3.6.1 (eXosip2/4.1.0)	2-< wan_default >				

SIP Extension								SIP Trunk		SIP Profile	
Index	Name	Address	Transport	Reg	Heartbeat	Status	Call In(F/T)	Call Out(F/T)	Profile		
1	SIP Trunk1	172.21.80.100:5566	UDP	off	off	NOREG/UP	0/0	0/0	1-<lan_def...		
2	0.157	172.18.0.157:5060	UDP	off	off	NOREG/UP	0/0	0/0	2-<wan_de...		

SIP Extension								SIP Trunk		SIP Profile	
Index	Name	Listening Addr	State	Current Call	Call In(F/T)	Call Out(F/T)					
1	lan_default	192.168.11.1:5060	RUNNING	0	0/0	0/0					
2	wan_default	172.18.0.147:5080	RUNNING	0	0/8	0/4					

Table 5-2 Explanation of SIP Parameters

Belong To	Parameter	Explanation
SIP Extension	Profile	The profile that is used by the SIP extension
	Status	SIP extension is registered or not. There are two statuses: Registered. Unregistered
Profile	Name	The name of the SIP profile
	Listening Address	The current listening address and port of SIP
	State	Green color means normal running, while red color means listening address and port of SIP is unavailable. There are two states :Running and Down
SIP Trunk	Heartbeat	If heartbeat is enabled, option message will be sent to peer device (the peer device is reachable)
	Status	Green color means available, while red color means abnormal, unavailable or prohibited. There are five statuses: Running, Reged/Up, Noreg/Up, Trying-Down, Fail-Wait
	Profile	The profile that is used by the SIP trunk

5.2.3 PSTN

On the **Status** → **PSTN** interface, information of FXS and FXO is shown. Green color means available or registered, while red color means abnormal, unregistered or prohibited.

Figure 5-4 Status of FXS and FXO

Status / PSTN					
FXS					
Port	Module State	Parameter Status	SIP Register Status	Hook State	
0	READY	OK	Reged(Master)	ONHOOK	
2	READY	OK	Not Config	ONHOOK	
FXO					
Port	Module State	Parameter Status	SIP Register Status	Hook State	Line State
1	READY	OK	Not Config	ONHOOK	ONLINE
3	READY	OK	Not Config	ONHOOK	OFFLINE

If 'SIP Register Status' is 'Registered', it means FXS and FXO have been **registered to SIP server** on the **Trunk** → **SIP/FXO** interface respectively. FXS can also be registered to SIP server on the **Extension** → **FXS** interface.

Table 5-2 Status Explanation of FXS and FXO

Belong To	Parameter	Explanation
FXS	Module Status	There are two module statuses: Ready and Config Failed
	Parameter Status	There are two parameter statuses: OK and error
	SIP Register Status	There are two SIP register statuses: Registered and Unregistered
	Hook State	There are two hook states: Onhook and Offhook
FXO	Module Status	There are two module statuses: Ready and Config Failed
	Parameter Status	There are two parameter statuses: OK and error
	SIP Register Status	There are two SIP register statuses: Registered and Unregistered
	Hook State	There are two hook states: Onhook and Offhook
	Line State	There are two hook states: Online and Offline

5.2.4 DHCP Client List

UC200-2S20 has a built-in DHCP server. When the DHCP server is enabled, it can assign IP addresses to the clients connected to it.

On the **Status → DHCP Client List** interface, information of DHCP clients connected to the UC200-2S2O gateway, such as client name, Mac address and IP address, is shown.

Figure 5-5 DHCP Client List

Status / DHCP Client List					
ID	Client Name	MAC Address	IP Address	Expiration	Status
1	GJFdeiphone	6C:8D:C1:05:A5:EE	192.168.11.173	2016-09-12 19:49:46	Online

5.2.5 Current Call

On **Status → Current Call** interface, the source, destination, caller number, called number, start time, answer time, state and duration of the current real-time call are shown. If there is no current call, no information will be shown

Figure 5-8 Current Call Information

Status / Current Call									
Index	Src	Dest	Caller	Called	Start Time	Answer Time	State	Duration	Filter

5.2.6 CDRs

Click **Status → CDRs**, and you can set query criteria to query the CDRs (Call Detailed Records) that you want on the displayed interface. Meanwhile, you are allowed to clear CDRs or export CDRs through clicking the **Empty** or **Export** button. The maximum number of CDRs that can be saved is 5000.

CDRs cannot be saved on the **Status → CDRs** interface unless the CDRs function has been enabled on the **System → Setting** interface.

Figure 5-9 CDRs

Status / CDRs											
CDRs Query Param											
Start Date	2018	7	1	End Date	2018	7	6	Caller		Called	
Source	Any			Destination	Any			Min Duration		Max Duration	
<input type="button" value="Query"/> <input type="button" value="Reset"/>											
CDRs List <input type="button" value="Empty"/> <input type="button" value="Export"/>											
Index	Caller	Source	Called	Destination	Start Time	End Time	Duration	Hangup By	Codec	Hangup Cause	Filter
No CDRs yet!											

5.2.7 Service

Click **Status** → **Service**, and the service status of UC200-2S2O is displayed. This function is enabled by default. The Web, SSH and Telnet service can be disabled and their ports can be modified on the **Network** → **Access Control** interface. If no running status is shown, it means exception has occurred on the UC200 device.

Besides, if syslog is disabled on the **System** → **Setting** interface, the logs cannot be uploaded to the server, but log service is still running.

Figure 5-10 Service Status



Status / Service	
Running Status	
Msg Service	Running
Switch Kernel Service	Running
Log Service	Running
Upgrade Service	Running
Web	Running
SSH	Running
Telnet	Running

5.2.8 About

Click **Status** → **About**, and the device model, device SN, hardware ID, MAC address, boot image, root image, WIFI driver , firmware version of the device are displayed.

Figure 5-11 About Status

5.3 System

Configurations for hostname, timezone, NTP, login username & password, operation log, service log, upgrade/backup/restore, IVR upload, command line, diagnostics and device reboot can be carried out in the System section.

5.3.1 Setting

On the **System** → **Setting** page, you can modify the device name (hostname), set a new timezone and synchronize local time. Meanwhile, you can enable CDRs, Syslog and built-in NTP server on the page.

Figure 5-12 Basic Setting

System / Setting

General

Hostname: UC200

Timezone: UTC

Local Time: 2018-07-06 01:48:54 [Sync with browser](#)

Date Format: YYYY-MM-DD

CDRs: Disable

Log

Service Log Level: Notice

Enable Syslog:

Time Synchronization

Enable builtin NTP server:



NTP server candidates:

- 0.pool.ntp.org
- 1.pool.ntp.org
- 2.pool.ntp.org
- 3.pool.ntp.org

[Cancel](#) [Save](#) [Reset](#)

Figure 5-4 Explanation of Basic Setting Parameters

Parameter	Explanation
Hostname	The name of the gateway. After it is configured, the name will be displayed on the left of the menu bar.
Timezone	You can choose a time zone you want. The default value is UTC (Universal Time Coordinated)
Local Time	The current time based on current time zone. It is synchronized with NTP
CDRs	If it is enabled, CDRs will be saved automatically. 5000 CDRs call be saved at most and they can be queried on the Status → CDRs interface. If it is disabled, CDRs will not be saved
Service Log Level	There are eight levels, including Debug, Info, Notify, Warning, Error, Critical, Alert and Emergency
Enable Syslog	Whether to enable syslog

Time Synchronization	If NTP server is enabled, the UC200-2S2O can be synchronized with the world standard time. Meanwhile, you're able to add or reduce NTP servers. Please consult local telecom operators or surf the internet for the address of NTP servers.
	Delete a NTP Server
	Add a NTP Server

5.3.2 User Manager

Click **System** → **User Manager**, and you can modify the username name and password for logging in the UC200-2S2O gateway. Factory defaults for username name and password are [admin](#) and [admin@123#](#) respectively, so it is advised to modify them for security consideration.

The abovementioned username and password are also used to log in Web Interface, Telnet and SSH.

Meanwhile, if you are the super administrator of the device, you can assign a role for other users. A user can be observer, operator or administrator. And you can select the permissions of viewing status, system, network, profile, extension, trunk and call control for the user.

Figure 5-13 Modify username, password

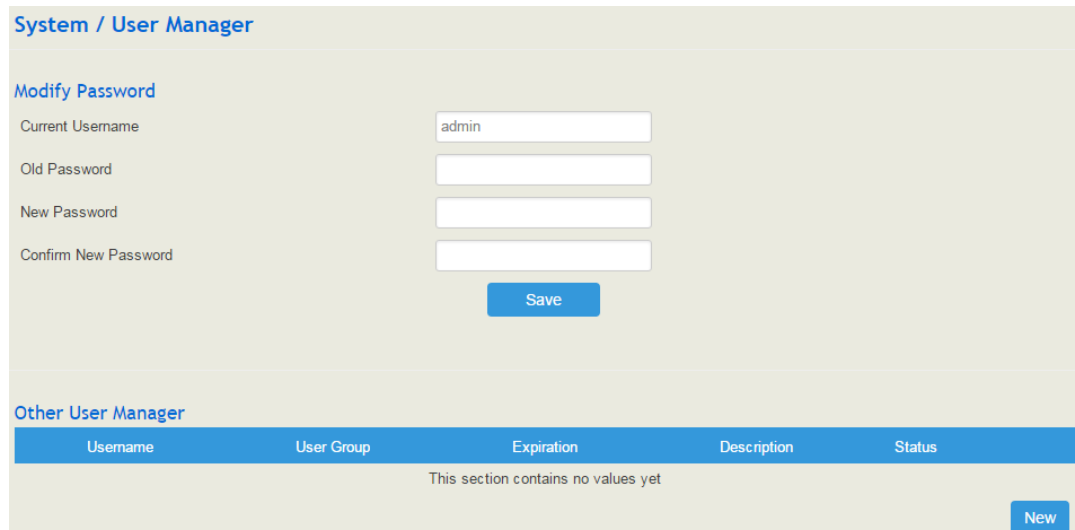

The screenshot shows the 'System / User Manager' web interface. It features a 'Modify Password' section with four input fields: 'Current Username' (containing 'admin'), 'Old Password', 'New Password', and 'Confirm New Password'. A 'Save' button is located below these fields. Below the 'Modify Password' section is a table titled 'Other User Manager' with columns for 'Username', 'User Group', 'Expiration', 'Description', and 'Status'. The table is currently empty, with a message 'This section contains no values yet' and a 'New' button at the bottom right.

Figure 5-14 Super Administrator to Add New User

System / User Manager / New User

Name:

User Group:

New Password:

Confirm New Password:

Expiration:

Description:

Status:

Web Access Permission:

- Status View
- System View
- Network View
- Profile View
- Extension View
- Trunk View
- Call Control View

Figure 5-5 Explanation of Provision Parameters

Parameter	Explanation
Name	The name of the new user. After it is established, the name and the password can be used to log onto the web page
User Group	You can assign a role for the new user. It can be administrator, operator or observer. The default value is administrator
New Password	The login password for the new user. The password must be 8-32 characters
Expiration	The expiry date of the user's access permission to this device
Status	Choose enable or disable.
Web Access Permission	select the permissions of viewing status, system, network, profile, extension, trunk and call control

5.3.3 Provision

Provision is used to make UC200-2S2O automatically upgrade with the latest firmware stored on an http server, an ftp server or a tftp server.

As for how to configure UC200-2S2O and http/ftp/tftp server for Provision, please make reference to the instruction guide of Provision.

Select the checkbox on the right of **Enable**, and you will see the following interface:

Figure 5-15 Provision

Table 5-6 Explanation of Provision Parameters

Parameter	Explanation
Periodic Check	Whether to enable periodic check. If it is enabled, the gateway will automatically check whether the firmware version stored on the URL is updated.
Check Interval	The interval to check whether the firmware version stored on the URL is updated. If it is 3600s, the gateway will check every 3600s.
URL	The URL of the http/ftp/tftp server: For example: ftp://172.16.77.200/home tftp://172.16.77.200/provision.xml http://test.domain.com/test
Username	The login username of the http/ftp/tftp server
Password	The login password of the http/ftp/tftp server

Note: Proxy Address, Proxy Username and Proxy Password are optional to be configured.

5.3.4 Operation Log

The logs tracing the operations carried out on the Web interface can be queried on the **System** → **Operation Log** page. You are allowed to set query criteria to query the logs that you want and to export the logs through clicking the **Export** button at the top-right corner.

Figure 5-16 Operation Logs

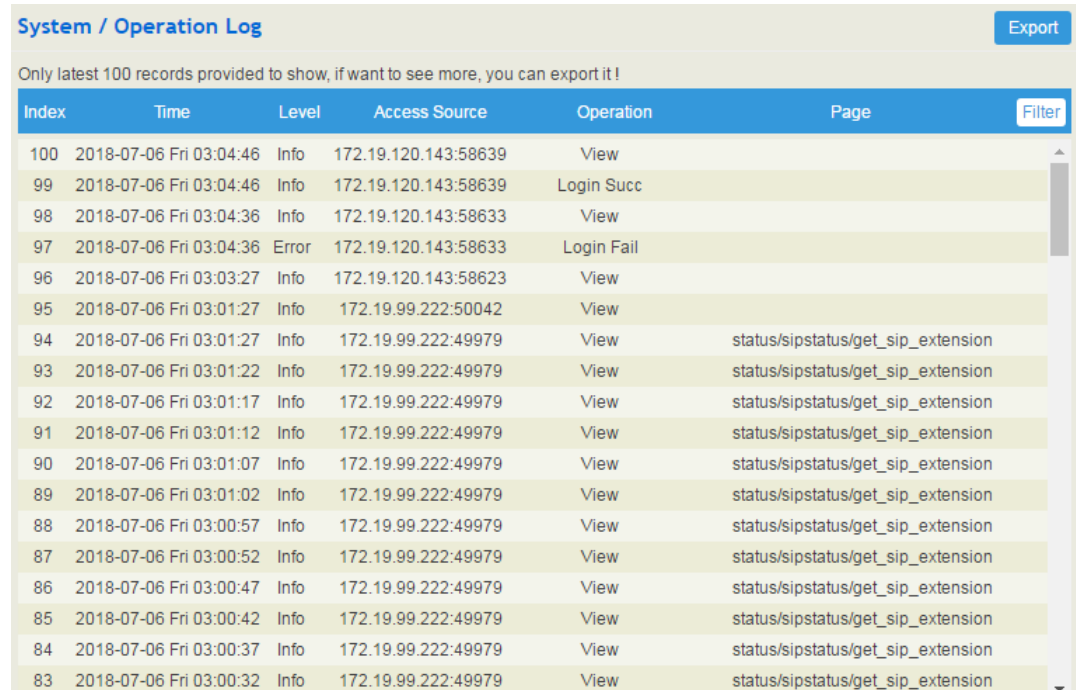

Index	Time	Level	Access Source	Operation	Page
100	2018-07-06 Fri 03:04:46	Info	172.19.120.143:58639	View	
99	2018-07-06 Fri 03:04:46	Info	172.19.120.143:58639	Login Succ	
98	2018-07-06 Fri 03:04:36	Info	172.19.120.143:58633	View	
97	2018-07-06 Fri 03:04:36	Error	172.19.120.143:58633	Login Fail	
96	2018-07-06 Fri 03:03:27	Info	172.19.120.143:58623	View	
95	2018-07-06 Fri 03:01:27	Info	172.19.99.222:50042	View	
94	2018-07-06 Fri 03:01:27	Info	172.19.99.222:49979	View	status/sipstatus/get_sip_extension
93	2018-07-06 Fri 03:01:22	Info	172.19.99.222:49979	View	status/sipstatus/get_sip_extension
92	2018-07-06 Fri 03:01:17	Info	172.19.99.222:49979	View	status/sipstatus/get_sip_extension
91	2018-07-06 Fri 03:01:12	Info	172.19.99.222:49979	View	status/sipstatus/get_sip_extension
90	2018-07-06 Fri 03:01:07	Info	172.19.99.222:49979	View	status/sipstatus/get_sip_extension
89	2018-07-06 Fri 03:01:02	Info	172.19.99.222:49979	View	status/sipstatus/get_sip_extension
88	2018-07-06 Fri 03:00:57	Info	172.19.99.222:49979	View	status/sipstatus/get_sip_extension
87	2018-07-06 Fri 03:00:52	Info	172.19.99.222:49979	View	status/sipstatus/get_sip_extension
86	2018-07-06 Fri 03:00:47	Info	172.19.99.222:49979	View	status/sipstatus/get_sip_extension
85	2018-07-06 Fri 03:00:42	Info	172.19.99.222:49979	View	status/sipstatus/get_sip_extension
84	2018-07-06 Fri 03:00:37	Info	172.19.99.222:49979	View	status/sipstatus/get_sip_extension
83	2018-07-06 Fri 03:00:32	Info	172.19.99.222:49979	View	status/sipstatus/get_sip_extension

Note: Operation logs are generally used to locate faults by device manufacturer.

5.3.5 Service Log

Service logs (the running logs of UC200-2S2O) can be exported on the **System** → **Service Log** page. Those logs are used for analyzing where a problem has occurred on the gateway.

Figure 5-17 Service Log



5.3.6 Config Changes Log

On the **System** → **Config Changes Log** page, the configurations changed by administrator on the Web interface of the gateway are recorded.

Figure 5-18 Config Changes Log



5.3.7 Backup/Restore/Upgrade

On the **System** → **Backup/Restore/Upgrade** page, you can back up or restore configuration data, and can upgrade UC200 to a new version. But you need to restart the device for the changes to take effect after executing restore or upgrade.

Figure 5-19 Backup/Restore/Upgrade

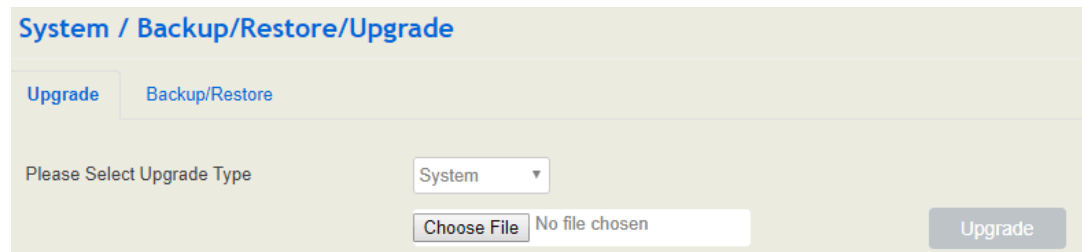

Note: the file you choose to be upgraded on the above page is a local file, while the version file upgraded through the Provision function is a file from http/ftp/tftp server.

System / Backup/Restore/Upgrade

Upgrade Backup/Restore

Choose backup files and download System Network Service **Download**

Reset to defaults System Network Service **Reset**

Restore from the backup No file chosen **Restore**

Restore to Modify history

Index	User	Modify history	
1	admin	2018-07-03 03:04:51	
2	admin	2018-07-03 09:00:28	
3	admin	2018-07-05 01:57:55	
4	admin	2018-07-05 02:06:14	
5	admin	2018-07-05 07:33:29	

Table 5-7 Explanation of Backup/Restore/Upgrade Button

Upgrade	Choose a file to be upgraded (which is provided by Shenzhen Dinstar Co., Ltd.), and then click Upgrade .
Download	You can download the configuration data to be backed up. Select any of the checkboxes on the left of System, Network and Service, and then click Download
Reset	Select any of the checkboxes on the left of System, Network and Service, and then click Reset , and configurations related to the selected part will be restored to factory defaults.
Restore	Choose a backup file, and then click Restore .

5.3.8 Voice

On the **System** → **Voice** interface, you can upload an IVR file according to your needs. At present, only wav audio file is allowed. The format of the uploaded wav audio file must be: monaural, 8000hz, 16bit, and size of no more than 550KB.

Figure 5-20 Upload IVR File

System / Voice

Type	Name	Description	Operation
Waiting Music	default waiting music	Default waiting/hold music, will play repeatedly	
IVR	default ivr	Default IVR welcome audio	

IVR 661 operator oper...wav **Upload**

The format of wav audio file should be monaural, 8000hz, 16bit, and a size of no more than 1Mb.

5.3.9 Command Line

On the **System** → **Command Line** page, some commonly-used command lines can be directly selected in the draw-down box, and therefore user has no need to enter command lines on Telnet. In this way, the efficiency of problem diagnostics is greatly improved.

Commonly-used command lines include fxo config, fxo status, fxs config, fxs status, sip status, sip profile and so on.

Figure 5-21 Command Line

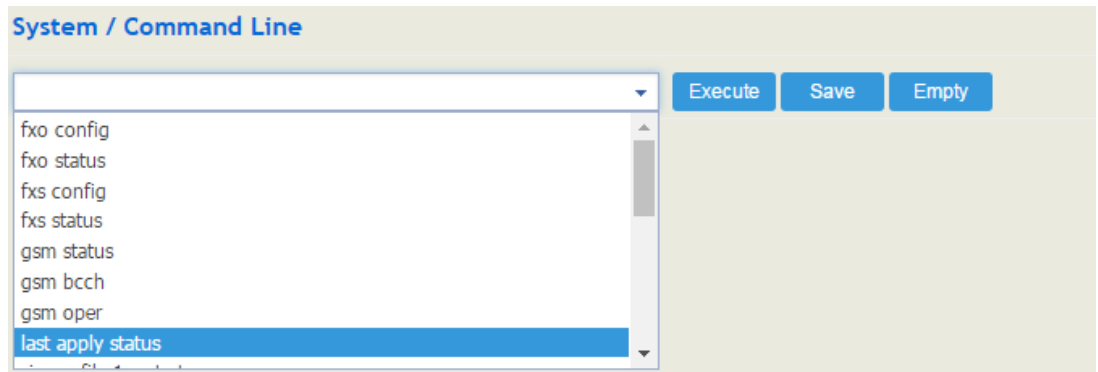

5.3.10 Diagnostics

Use a telephone line to connect the FXS port and the FXO port. On the **System** → **Diagnostics** page, select a module (FXS/FXO) that you want to diagnose. Click Start, and the gateway will begin to diagnose the selected module.

If the progress bar of diagnostics is green, it means the module that is diagnosed works well; if the progress bar is red, it means the module that is diagnosed is faulty.

Figure 5-22 Diagnostics

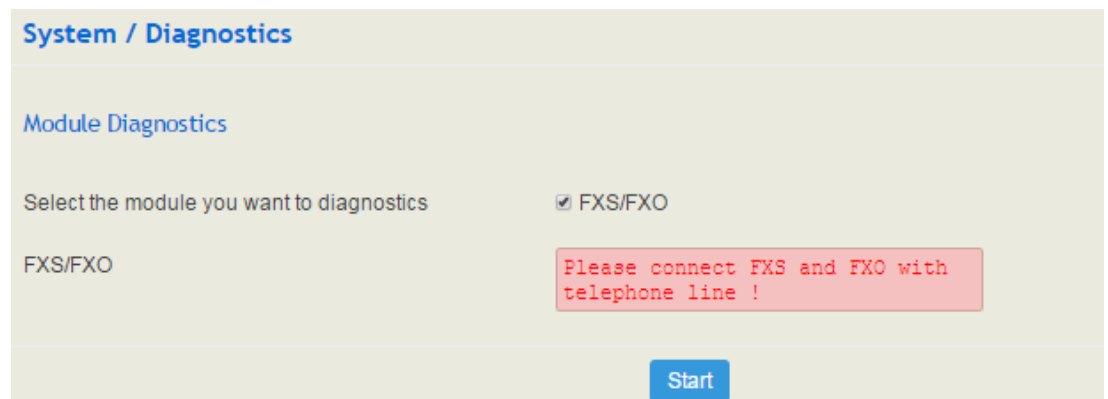

5.3.11 Cloud Server

UC200-2S2O provides cloud service which is a kind of high-efficient and reliable computing service with flexible processing capability. You input the IP address, port and password of a cloud server, and then the UC200-2S2O device can interwork with the cloud server.

5.3.12 API

UC200 provides API to interwork with other devices or platforms.

Figure 5-23 API

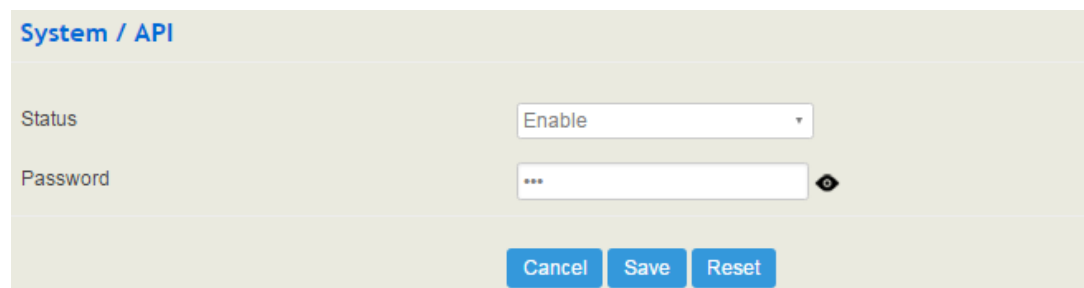

The screenshot shows the 'System / API' configuration page. It features a 'Status' dropdown menu currently set to 'Enable' and a 'Password' input field containing '***' with a visibility toggle icon. At the bottom of the form, there are three buttons: 'Cancel', 'Save', and 'Reset'.

5.3.13 Reboot

On the **System** → **Reboot** page, you can click **Perform Reboot** to reboot the UC200-2S2O gateway. After the device is rebooted, those configurations that have been saved will remain unchanged.

Figure 5-25 Reboot Device



The screenshot shows the 'System / Reboot' page with a single prominent blue button labeled 'Perform reboot'.

5.4 Network

UC200-2S2O works in two modes: route mode and bridge mode. When it is under the route mode, the IP of WAN must be different from the IP of LAN. But when it is under the bridge mode, the IP of WAN and the IP of LAN are the same.

5.4.1 Setting

On the **Network** → **Setting** page, you can set the IP address of WAN port and LAN port.

Under the route mode, the default IP address of WAN port is a DHCP IP address, while the default IP address of the LAN port is 192.168.11.1.

In fact, there are three kinds of IP addresses for selection for WAN port and LAN port, including Static IP address, DHCP and PPPOE.

DHCP: Obtain IP address automatically.

UC200-2S20 is regarded as a DHCP client, which sends a broadcast request and looks for a DHCP server to answer. Then the DHCP server automatically assigns an IP address to the UC200-2S20 from a defined range of numbers.

Figure 5-26 Default IP Address under Route Mode

The screenshot displays the 'Network / Setting' configuration page. It is divided into sections for 'WAN' and 'LAN' settings. At the top, the 'Network Model' is set to 'Route'. Under the 'WAN' section, the 'Protocol' is set to 'DHCP', and two checkboxes, 'Obtain DNS server address automatically' and 'Disable Private Internets(RFC2918) DNS responses', are both checked. The 'MTU' is set to 1500. Under the 'LAN' section, the 'IP Address' is 192.168.11.1, the 'Netmask' is 255.255.255.0, and the 'MTU' is 1500. At the bottom right, there are three buttons: 'Cancel', 'Save', and 'Reset'.

Section	Parameter	Value
Network Model	Network Model	Route
	WAN	
WAN	Protocol	DHCP
	Obtain DNS server address automatically	<input checked="" type="checkbox"/>
	Disable Private Internets(RFC2918) DNS responses	<input checked="" type="checkbox"/>
	MTU	1500
LAN	IP Address	192.168.11.1
	Netmask	255.255.255.0
	MTU	1500
	Buttons: Cancel, Save, Reset	

Figure 5-27 Set WAN IP as DHCP IP

The screenshot shows the WAN configuration page with the following settings:

Protocol	DHCP
Obtain DNS server address automatically	<input checked="" type="checkbox"/>
Disable Private Internets(RFC2918) DNS responses	<input checked="" type="checkbox"/>
MTU	1500

Note: When WAN IP is set as DHCP IP, please ensure that there is DHCP server working normally in the network.

Static IP Address:

Static IP address is a semi-permanent IP address and remains associated with a single computer over an extended period of time. This differs from a dynamic IP address, which is assigned *ad hoc* at the start of each session, normally changing from one session to the next.

If you choose static IP address, you need to fill in the following information:

- IP Address: the IP address of the WAN port of the UC200-2S2O;
- Netmask: the netmask of the router connected the UC200-2S2O;
- Default Gateway: the IP address of the router connected the UC200-2S2O;
- Use custom DNS server: the IP address of the DNS server

Figure 5-28 Set WAN IP as Static Address

The screenshot shows the WAN configuration page with the following settings:

Protocol	Static address
IP Address	172.16.80.117
Netmask	255.255.0.0
Default Gateway	172.16.1.7
Use custom DNS server	202.96.128.166

PPPoE:

PPPoE is an acronym for point-to-point protocol over Ethernet, which relies on two widely accepted standards: PPP and Ethernet. PPPoE is a specification for connecting the users on an Ethernet to the Internet through a common broadband medium, such as a single DSL line, wireless device or cable modem. PPPOE IP address refers to IP address assigned through the PPPoE mode.

If you choose PPPoE, you need to fill in to fill in the following information:

- Username: the account name of PPPoE
- Password: the password of PPPoE
- Server Name: the name of the server where PPPoE is placed

Figure 5-29 Set WAN IP as PPPoE IP

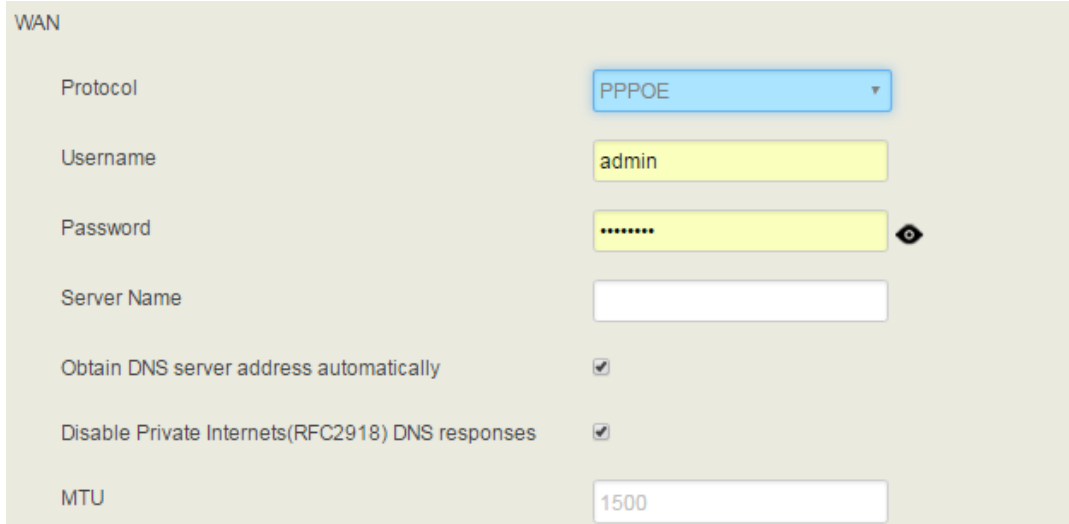

The screenshot displays the WAN configuration interface. The 'Protocol' is set to 'PPPOE'. The 'Username' field contains 'admin'. The 'Password' field is masked with dots and has a visibility toggle icon. The 'Server Name' field is empty. The 'Obtain DNS server address automatically' and 'Disable Private Internets(RFC2918) DNS responses' options are checked. The 'MTU' field is set to '1500'.

Field	Value
Protocol	PPPOE
Username	admin
Password
Server Name	
Obtain DNS server address automatically	<input checked="" type="checkbox"/>
Disable Private Internets(RFC2918) DNS responses	<input checked="" type="checkbox"/>
MTU	1500

5.4.2 Access Control

The access ports of Web, Telnet and SSH, as well as relevant on-off controls, can be configured on the **Network** → **Access Control** page. Web supports http and https, while SSH supports OAuth 2.0 protocol.

Figure 5-34 Access Control

The screenshot displays the 'Network / Access Control' configuration page. It is divided into three sections: Web Server, Telnet, and SSH. Each section has a title and several configuration options.

Web Server

- HTTP Port: 80
- Allow WAN access:
- HTTPS Port: 443
- Allow WAN access:

Telnet

- Enable:
- Port: 23
- Allow WAN access:

SSH

- Enable:
- Port: 22
- Allow WAN access:

At the bottom of the page, there are three buttons: Cancel, Save, and Reset.

5.4.3 Firewall

If the UC200-2S2O works under the route mode, you can choose to enable the firewall and set filter rules to accept or reject certain destination IP addresses.

Configuration Procedures:

1. Select **On** in the drop-down box on the right of **Filter Rules Control**
2. Select filter action, accept or reject;
3. Click the **New** button;
4. Fill in information of filter rule;
5. Click the **Save** button to save the configuration.



Figure 5-35 Firewall

Network / Firewall

Filter Rules Control

Default action outside the filter rules

Filter Rules

Index	Name	Protocol	LAN IP/Port/MAC	WAN IP/Port	Action
1	abc	TCP	192.16.11.1/*	172.16.80.117/1	Accept  

Note:

: Edit information for the corresponding filter rule.



: Delete the corresponding filter rule.

/*: Information of Source or Destination is not completely filled in.

Figure 5-36 Create Filter Rule

Network / Firewall / Filter Rules / New

Index

Name

Protocol

LAN IP

LAN Port

LAN MAC

WAN IP

WAN Port

Action

Table 5-12 Explanation of Parameters for Filter Rule

LAN IP	The IP address that you want UC200 to accept or reject. It is the IP address of a host from local-area network; it can also be a string of
--------	--

	IP addresses, for example, 172.16.11.1/15.
LAN Port	The port of LAN host which the accepted or rejected IP address belongs to
LAN MAC	The Mac of the LAN host which the accepted or rejected IP address belongs to
WAN IP	The IP address that you want UC200 to accept or reject. It is the IP address of a host from wide-area network; it can also be a string of IP addresses, for example, 152.16.11.11/19.
WAN Port	The port of WAN host which the accepted or rejected IP address belongs to
Action	Choose accept or reject

5.4.4 DHCP Server

If there is a need, you can choose to enable the built-in DHCP server of UC200-2S20 to assign IP addresses to PC or other clients that are in the same local-area network with UC200. Under this condition, the UC200-2S20 gateway works like a router.

Figure 5-37 Enable DHCP Server

Network / DHCP

DHCP Server: Enable

Start Address: 192.168.11.99

End Address: 192.168.11.198

Leasetime(Hour): 12

Gateway:

Master DNS:

Slave DNS:

Buttons: Cancel, Save, Reset

Table 5-13 Explanation of Parameters for DHCP Server

Start Address	The start IP address of the address pool from which an IP address will be chosen
End Address	The end IP address of the address pool from which an IP address will be chosen

Lease Time	The validity period of the IP address to be assigned
Gateway	The gateway of the IP address to be assigned, it is optional to fill in
Master DNS	The master DNS of the client whose IP address is assigned by the built-in DHCP server; it is optional to fill in
Slave DNS	The slave DNS of the client whose IP address is assigned by the built-in DHCP server; it is optional to fill in

5.4.5 Port Mapping

When the UC200-2S20 works under the route mode, port mapping allows the UC200-2S20 in the public network to visit a client in the local-area network.

Configuration Procedures:

1. Click **Network** → **Port Mapping**, and the following interface will be shown.

Figure 5-38 Port Mapping

2. Click the **New** button.
3. Fill in information on the following interface.

Figure 5-39 Create New Port Mapping

Table 5-14 Explanation of Parameters for Port Mapping

Name	The name of this port mapping
WAN Port	The WAN port of the UC200-2S2O in the public network, which is to visit a client in local-area network
Protocol	Choose TCP, UDP or TCP/UDP
LAN IP	The IP address of the to-be-visited client in local-area network
LAN Port	The port of the to-be-visited client in local-area network (this port cannot conflict with the port of UC200-2S2O)
Status	Chose enable or disable

4. Click the **Save** button to save the above configurations.

5.4.6 DMZ Setting

When the UC200-2S2O gateway works under the route mode and the DMZ service is enabled, this UC200-2S2O gateway in the public network are allowed to have direct access to the clients in the DMZ (**demilitarized zone**).

Figure 5-40 Enable DMZ Service

The screenshot shows the 'Network / DMZ' configuration page. It features a 'DMZ Status' dropdown menu set to 'Enabled' and a 'DMZ IP Address' text input field containing '192.168.1.123'. At the bottom, there are three buttons: 'Cancel', 'Save', and 'Reset'.

5.4.7 Diagnostics

On the **Network** → **Diagnostics** page, you can use three network utilities including Ping, Traceroute and Nslookup to diagnose the network, and can capture data packages of the available network ports.

Figure 5-41 Network Diagnostics

The screenshot shows a web interface for network diagnostics. It has a header 'Network / Diagnostics'. Below it, there's a section 'Network Utilities' with three input boxes and buttons labeled 'Ping', 'Traceroute', and 'Nslookup'. The next section is 'Network Capture', which contains several configuration options: 'Capture Mode' (dropdown menu set to 'Custom'), 'Network Interface' (dropdown menu set to 'WAN'), 'Logical Type' (dropdown menu set to 'OR'), and four input fields for 'Source IP', 'Source Port', 'Destination IP', and 'Destination Port'. At the bottom of this section, there are four checkboxes for 'Protocol': 'TCP', 'UDP', 'ICMP', and 'ARP'. A 'Start' button is located at the bottom right of the Network Capture section.

Ping is used to examine whether a network works normally through sending test packets and calculating response time.

Instructions for using Ping:

1. Enter the IP address or domain name of a network, a website or a device in the input box of Ping, and then click **Ping**.
2. If related messages are received, it means the network works normally; otherwise, the network is not connected or is connected faultily.

Traceroute is used to determine a route from one IP address to another.

Instruction for using Traceroute:

1. Enter the IP address or domain name of a destination device in the input box of Traceroute, and then click **Traceroute**.
2. View the route information from the returned message.

Nslookup (Name Server Lookup) is a network command-line tool to obtain domain name of internet or to diagnose the problems of DNS.

Instruction for using Nslookup:

1. Enter a domain name and then click **Nslookup**.
2. View the DNS information from the returned message.

Network Capture

On the following interface, you can capture data packages of the available network ports. You can also set source IP, source port, destination IP or destination port to capture the packages that you want.

Figure 5-42 Network Capture

The screenshot shows a web interface titled "Network Capture". It contains the following elements:

- Capture Mode:** A dropdown menu with "Custom" selected.
- Network Interface:** A dropdown menu with "WAN" selected.
- Logical Type:** A dropdown menu with "OR" selected.
- Source IP:** An empty text input field.
- Source Port:** An empty text input field.
- Destination IP:** An empty text input field.
- Destination Port:** An empty text input field.
- Protocol:** Four checkboxes for "TCP", "UDP", "ICMP", and "ARP", all of which are currently unchecked.
- Start:** A blue button with the text "Start" in white.

Note: If there are multiple source or destination IP addresses, please use '|' to separate them, for example, 172.16.115.12|172.16.115.15.

Logical Type: if 'OR' is selected, only the packages from source IP to destination IP or from destination IP to source IP will be captured. If 'And' is selected, packages from source IP to destination IP and from destination IP to source IP will be captured.

After package capturing is completed, save the captured packages on a computer and then use a tool to analyze them.

5.4.8 Static Route

On the **Network → Static Route** page, you can configure static routes for the network.

Figure 5-44 Create New Static Route

The screenshot shows a web interface for creating a new static route. The title is "Network / Static Route / New". The form contains the following fields:

- Index: 1
- Name: Static Route-1
- Target IP: 192.168.1.102
- Netmask: 255.255.255.0
- Gateway: 172.16.1.5
- Interface: WAN
- Status: Enable

At the bottom of the form, there are three buttons: "Cancel", "Save", and "Reset".

Table 5-16 Explanation of Parameters for Static Route

Name	The name of the static route
Target IP	The destination IP address of the static route
Netmask	The netmask of the static route, default: 255.255.255.0
Gateway	The IP address of the outbound gateway of the static route
Interface	The outbound interface of the static route, namely WAN port or LAN port
Status	The static route is enabled or disabled

5.4.9 UPnP Client

UC200-2S2O can serve as an UPnP client. When UC200-2S2O is deployed at a local-area network and its outbound router supports the UPnP function, you can enable the UPnP function on the **Network → UPnP Client** page of the UC200-2S2O device, and thus its outbound router is notified by the UPnP protocol to carry out port mapping.

For example, the public IP address of outbound router is 172.16.20.12, and the external port configured on UC200-2S2O is 8080. When UPnP HTTP is enabled, the router will create a port mapping from external HTTP port 8080 to intranet HTTP port 80, and thus clients in public network can visit the UC200-2S2O gateway which is in local-area network through entering 72.16.20.12:8080.

Figure 5-45 UPnP Client

Network / UPnP Client

Enable HTTP

External Port

Enable HTTPS

Enable Telnet

Enable SSH

5.4.10 Hosts

On the **Network** → **Hosts** page, you can add a host file. After enabling the hosts file, you can visit the corresponding host by inputting the alias or domain name of the host. The format of the hosts file is as follows: IP address host alias/domain name.

The hosts file contains the mapping relationship between IP address and host name/alias/domain name. And the mapping relationship allows quick and convenient access to the host.

Figure 5-49 Enable Hosts File

Network / Hosts

Status

1	172.16.11.113 Host Alias
---	--------------------------

Hosts List

5.5 Profile

The Profile menu includes the following sub-menus: SIP, FXS/FXO, Codec, Number, Time, Manipulation, Speed Dial, Dialplan, Recording and Voicemail.

5.5.1 SIP

On the **Profile** → **SIP** page, you can set SIP profile which will include SIP information such as listening port and caller/callee number source. SIP profiles will be used in extension and trunk. Multiple SIP profiles can be configured for one UC200-2S2O device, so you can choose different SIP profiles according to different needs.

Figure 5-50 Configure SIP Profile

Profile / SIP / Edit	
Index	1
Name	lan_default
Local Listening Interface	LAN
Local Listening Port	5060
Progress Timeout(s)	55
DTMF Type	RFC2833
RFC2833-PT	101
PRACK	Off
Session Timer	Off
Caller Number Source	From: User Part
Called Number Source	To: User Part
Inbound Codec Negotiation Priority	Remote
Inbound Codec Profile	1-< default >
Outbound Codec Profile	1-< default >
CNG(Comfort Noise Generator)	On
Bypass Media(SIP to SIP)	Off

Detect Extension is Online	Off
Allow Unknown Call	Off
Inbound Source Filter	0.0.0.0/0 
QoS	Off
User Agent	Hostname / Full Firmware Ver
Timer T1(ms)	500
Timer T2(ms)	4000
Timer T4(ms)	4000
Timer T1X64(ms)	32000

Table 5-19 Explanation of Parameters for SIP Profile



Name	The name of the SIP profile
Local Listening Interface	The local listening interface of this SIP profile. It can be WAN port, LAN port, Open VPN, L2TP and PPTP. If the SIP profile is used by a SIP trunk, the interface filled in here is the listening port for the SIP trunk.
Local Listening Port	The local listening port of this SIP profile. If the SIP profile is used by a SIP trunk, the port filled in here is the listening port for the SIP trunk.
DTMF Type	DTMF is short for Dual Tone Multi Frequency There are three DTMF modes, including SIP Info, INBAND, RFC2833
RFC2833-PT	RFC2833 payload coding
PRACK	Provisional Response ACKnowledgement
Session Timeout	The validity period of a SIP session. When a SIP session times out, an invite message needs to be sent to refresh the session, otherwise, the session ends; It is 1800 seconds by default
Inbound Codec Negotiation Priority	To take the remote device or the local device as priority for inbound codec negotiation Assume local device supports PCMA, PCMU, G.729 and G.723, while the remote device supports G.723 and G.729



	If remote device is taken as codec negotiation priority, G.723 will be the codec mode, since the remote device supports G.723 and G.729 and G.723 is prior to G.729
Inbound Codec Profile	The codec supported by SIP for inbound calls
Outbound Codec Profile	The codec supported by SIP for outbound calls
Bypass Media(SIP to SIP)	Whether to allow SIP to communicate with the server directly
Detect Extension is Online	Whether to detect the SIP extension using this SIP profile is online or not
Allow Unknown Call	If this function is enabled, incoming calls from unknown sources are allowed. Unknown sources are those IP addresses that do not fall into the source range configured for SIP trunks or SIP extensions
Inbound Source Filter	The source of inbound calls, which is allowed. It can be an IP address or a network segment. If it is a network segment, the format is 172.16.0.0/16 or 172.16.0.0/255.255.0.0, which means calls from the network segment of 172.16 is allowed to come in. 0.0.0.0 means calls of any source is allowed to come in
QoS	Whether to enable QoS. QoS is a technology used to solve network delay or congestion

5.5.2 FXS/FXO

On the **Profile** → **FXS/FXO** page, you can configure the driving parameters of FXS port and FXO port, including tone standard, digit timeout, dial timeout, ringing timeout, hook-flash detection, DTMF parameters, CID-related parameters, impedance, dialplan and so on.

Figure 5-51 FXS/FXO Profile

Profile / FXS						
Index	Name	Tone Group	Digit Timeout(s)	Dial Timeout(s)	Ring Timeout(s)	No Answer Timeout(s)
1	default	China	4	10	55	55
 						
New						

Profile / FXO						
Index	Name	Tone Group	Digit Timeout(s)	Dial Timeout(s)	Ring Timeout(s)	No Answer Timeout(s)
1	default	China	4	10	55	55
 						
New						

Click , and corresponding configuration interface will pop up.

Figure 5-52 Configure FXS Parameters

Profile / FXS / Edit

Index	1
Name	<input type="text" value="default"/>
Tone Group	<input type="text" value="China"/>
Digit Timeout(s)	<input type="text" value="4"/>
Dial Timeout(s)	<input type="text" value="10"/>
Ring Timeout(s)	<input type="text" value="55"/>
No Answer Timeout(s)	<input type="text" value="55"/>
Flash Detection	<input checked="" type="checkbox"/>
Min Time (ms)	<input type="text" value="100"/>
Max Time (ms)	<input type="text" value="400"/>
DTMF Parameters	
DTMF Send Interval(ms)	<input type="text" value="200"/>
DTMF Duration(ms)	<input type="text" value="200"/>
DTMF Gain	<input type="text" value="-6dB"/>
DTMF Detect Threshold	<input type="text" value="-30dB"/>
DTMF Terminator	<input type="text" value="#"/>
Send DTMF Terminator	<input type="text" value="Off"/>
CID Send Mode	<input type="text" value="FSK-BEL202"/>
Message Mode	<input type="text" value="MDMF"/>
Message Format	<input type="text" value="Display Name and CID"/>
CID Send Timing	<input type="text" value="Send After RING"/>
Delay Timeout After Ring(ms)	<input type="text" value="2000"/>
Impedance	<input type="text" value="600 Ohm"/>
REN(Ringer Equivalency Number)	<input type="text" value="1"/>
Send Polarity Reverse	<input type="text" value="On"/>
Send Flash Hook via SIP INFO / RFC2833	<input type="text" value="Off"/>
Offhook Current Detect Threshold	<input type="text" value="12mA"/>
Onhook Current Detect Threshold	<input type="text" value="10mA"/>
Dialplan	<input type="text" value="Off"/>

Table 5-20 Explanation of FXS Parameters

Name	The name of this FXS profile
Tone Group	The national standard of dialing tone, busy tone and ring tone; default value is China
Digit Timeout (s)	The timeout value for dialing a digit of a telephone number; When the time of dialing a digit exceeds this value, the system will think the dialing has completed; Default value is 4 seconds
Dial Timeout (s)	The timeout value for dialing the first telephone number after off-hook; Default value is 10 seconds
Ring Timeout(s)	The timeout value for the ringing of the analog phones of the FXS port when there are incoming calls
No Answer Timeout (s)	The timeout value for ending a call which goes out through the FXS port, when nobody answers the call.
Flash Detection	Whether to enable flash-hook detection; If flash detection is not enabled, the press on flash-hook will be ignored and won't be processed.
Flash Detection: Min Time(ms)/ Max Time(ms)	Min Time: when flash-hook detection is enabled, if the time of the press on the flash-hook is less than this minimum time, the press will be ignored and won't be processed. Max Time: when flash-hook detection is enabled, if the time of the press on the flash-hook is longer than this maximum time, the phone will be hanged up.
DTMF Send Interval(ms)	The minimum interval between the sending of two DTMF tone DTMF: Dual Tone Multi Frequency
DTMF Gain	Signal gain of DTMF
DTMF Duration (ms)	The minimum duration of a DTMF tone
DTMF Detect Threshold	The threshold for the device to detect DTMF
DTMF Terminator	The terminator for ending DTMF detection. It means when the terminator is detected, the system will think the dialing is completed and begin to process call.
Send DTMF Terminator	Whether to send DTMF terminator
CID Send Mode	The modes of sending CID to the called phone when there are incoming calls, including FSK and DTMF; FSK: Frequency-shift keying; CID: Caller ID
Message Mode	The message modes to display caller information, including SDMF and MDMF

Message Format	The message formats to display caller information, including Display Name and CID, Only display Name, Only display CID
Send CID Before Ring	If it is enabled, the CID will be shown before ringing; otherwise, CID will be displayed after ringing
Send CID After Ring(ms)	If it is enabled, the CID will be shown after ringing; otherwise, CID will be displayed before ringing
Delay Timeout After Ring (ms)	The maximum interval between ringing and displaying of CID
Impedance	The impedance (SLIC) matched with analog phones
REN(Ringer Equivalency Number)	REN is used to determine how many devices can be connected by FXS/FXO telephone lines. The range of REN is from 1 to 4
Polarity Reverse	If polarity reverse is on, call tolls will be calculated based on the changes in voltage. If polarity reverse is off, you need to set the time for offhook detect and call tolls will be calculated starting from the set time
Send Flash Hook via SIP INFO	If this parameter is on, signal of flash-hook is sent via SIP INFO
Offhook Current Detect Threshold	The current threshold used to detect the offhook status of FXS/FXO
Onhook Current Detect Threshold	The current threshold used to detect the onhook status of FXS/FXO
Dialplan	The rules for dialing. The UC200-2S2O device supports regular expression. Please make reference to Profile → Dialplan section.

Figure 5-53 Configure FXO Parameters

Profile / FXO / Edit

Index	1
Name	<input type="text" value="default"/>
Tone Group	<input type="text" value="China"/>
Digit Timeout(s)	<input type="text" value="4"/>
Dial Timeout(s)	<input type="text" value="10"/>
Ring Timeout(s)	<input type="text" value="55"/>
No Answer Timeout(s)	<input type="text" value="55"/>
Detect Polarity Reverse	<input type="text" value="Off"/>
Delay Offhook(s)	<input type="text" value="3"/>
Detect Caller ID	<input type="text" value="Detect after ring"/>
DTMF Detect Timeout(ms)	<input type="text" value="5000"/>
Dial Delay(ms)	<input type="text" value="400"/>
DTMF Parameters	
DTMF Send Interval(ms)	<input type="text" value="200"/>
DTMF Duration(ms)	<input type="text" value="200"/>
DTMF Gain	<input type="text" value="-6dB"/>
DTMF Detect Threshold	<input type="text" value="-30db"/>
DTMF Terminator	<input type="text" value="#"/>
Send DTMF Terminator	<input type="text" value="Off"/>
BusyTone Detect Parameters	
Detect Tone counts	<input type="text" value="8"/>
Detect Tone Delta(ms)	<input type="text" value="50"/>
Intermittent Ratio	<input type="text" value="1:1"/>
Dialplan	<input type="text" value="Off"/>

Table 5-21 Explanation of FXO Parameters

Name	The name of this FXO profile
Tone Group	The national standard of dialing tone, busy tone and ring tone; default value is China
Digit Timeout (s)	The timeout value for dialing a digit of a telephone number; When the time of dialing a digit exceeds this value, the system will think the dialing has completed; Default value is 4 seconds
Dial Timeout (s)	The timeout value for dialing the first telephone number after off-hook; Default value is 10 seconds
Detect Polarity Reverse	Whether to enable 'detect polarity reverse'. If 'detect polarity reverse' is on, call tolls will be calculated based on the changes in voltage. If 'detect polarity reverse' is off, you need to set the time for offhook delay and call tolls will be calculated starting from the set time.
Detect Caller ID	Detect before ring: the CID will be shown before ringing; otherwise, CID will be displayed after ringing; Detect after ring: the CID will be shown after ringing; otherwise, CID will be displayed before ringing Off: the CID will not be shown
DTMF Detect Timeout(s)	The timeout value to detect CID (in DTMF format)
Dial Delay(ms)	The delay time of dialing for FXO
DTMF Send Interval(ms)	The minimum interval between the sending of two DTMF tone DTMF: Dual Tone Multi Frequency
DTMF Duration (ms)	The minimum duration of a DTMF tone
DTMF Gain	Signal gain of DTMF
DTMF Detect Threshold	The threshold for the device to detect DTMF
DTMF Terminator	The terminator for ending DTMF detection. It means when the terminator is detected, the system will think the dialing is completed and begin to process call.
Send DTMF Terminator	Whether to send DTMF terminator
Detect Tone counts	the number of busy tone notes to be checked
Detect Tone Delta	the error size to check the busy tone
Intermittent Ratio	The intermittent ratio to detect busy tone

Dialplan	The rules for dialing. The UC200-2S2O device supports regular expression. Please make reference to Profile → Dialplan section.
----------	---

5.5.3 Codec

UC200-2S2O supports four codec modes, including G729, G723, PCMU and PCMA. You can adjust the priority of these four modes according to you needs.

Figure 5-54 Add or Delete Codec Profile

The screenshot shows a configuration form titled "Profile / Codec / New". It includes the following fields and options:

- Index:** A dropdown menu set to "2".
- Name:** A text input field containing "Codec2".
- Audio Codec:** A list of four items, each with a dropdown for the codec name and a dropdown for the bit rate, followed by a delete icon (red circle with an 'X'):
 - PCMA, 20ms
 - G723, 30ms
 - G729, 20ms
 - PCMU, 20ms
- Video Codec:** A dropdown menu set to "VP8", followed by delete (red circle with an 'X') and add (green circle with a '+') icons.
- Buttons:** "Cancel", "Save", and "Reset" buttons at the bottom.



: Edit codec profile.



: Delete the corresponding codec profile or a codec mode.



: Create a new codec profile.

5.5.4 Number

On the **Profile → Number** page, you can set a prefix for caller numbers or called numbers. When the prefix of a caller number or a called number matches the set prefix, the call will be passed to choose a route.

Figure 5-55 Number Profile

The screenshot shows a table titled "Profile / Number" with the following columns and data:

Index	Name	Caller Prefix	Caller Length	Called Prefix	Called Length	
1	Number 1	0755	*	*	*	

Below the table is a blue "New" button.



: Edit number profile.



: Delete the corresponding number profile

Click **New**, and you will see the following interface:

Figure 5-56 Create Number Profile

Profile / Number / New

Index: 1

Name: test

Caller Number

Length: 5

Prefix:

- 1 #
- 2 *

Called Number

Length: 5

Prefix:

- 1 #
- 2 *

Buttons: Cancel, Save, Reset

Table 5-22 Explanation of Number Parameters

Name	The name of the number profile
Prefix of Caller Number	The prefixes of caller numbers. You can input multiple prefixes by pressing Enter button. It supports regular expression
Prefix of Called Number	The prefixes of called numbers. It supports regular expression. You can input multiple prefixes by pressing Enter button.
Length	The length of the caller number or called number. For example, : 4 6 7 means the calling number or called number must be 4 digits, 6

	digits or 7 digits except the prefix
--	--------------------------------------

Regex (Regular Expression) Syntax

Table 5-3 Explanation of frequently-used metacharacters in Regex

^	Matches the starting position in a number string. For example, ^134 matches the numbers starting with 134
\$	Matches the ending position of a string. For example, 2\$ matches the numbers ending with 2.
	Separates alternate possibilities. For example, 2 3 4 means 2,3or 4.
\	Marks the next character as a special character, a literal, a backreference, or an octal escape
[]	Matches a single character that is contained within the bracket. For example, [123] matches 1, 2, or 3. [0-9] matches any digit from "0" to "9".
[^]	Matches any one character except those enclosed in []. For example, [^9] matches any character except 9.
.	Matches any single character except the newline character. For example, 3.4 matches 314, 324, 334, 344.
?	Indicates there is zero or one of the preceding element. For example, colou?r matches both color and colour
*	Indicates there is zero or more of the preceding element. For example, ab*c matches ac, abc, abbc, abbbc, and so on.
+	Indicates there is one or more of the preceding element. For example, ab+c matches abc, abbc, abbbc, and so on, but not ac
\d	Mark any digit, equal to [0-9]

Examples:

^0755	Matches the phone numbers with starting digits of 0755.
^0755 ^8899 ^0110	Matches the phone numbers with starting digits of 0755, 8899 or 0110.
^[1][358][0-9]{9}\$	Matches the phone numbers with the first digit as 1, the second digit as 3, 5 or 8, the left nine digits as any of 0 to 9.

Note: the matching of number prefix also supports some digits that are not conform to the format of regular expression. For example, 0755 matches the numbers starting with 0755, and 0755|8899|0110 matches the numbers starting with 0755, 8899 or 0110.

5.5.5 Time

On the **Profile → Time** page, you can set a time period for calls to choose routes. If the local time when a call is initiated falls into the set time period, the call will be passed to choose the corresponding route.

Click the **New** button, and you will see the following interface:



Figure 5-57 Create Time Profile

The screenshot shows a web interface titled "Profile / Time / New". It contains the following fields and controls:

- Index:** A dropdown menu with the value "1" selected.
- Name:** A text input field containing "Time Profile 1".
- Date Period:** A text input field containing "2018-07-04~2018-07-06" with a green plus icon to its right.
- Weekday:** A set of checkboxes for "Mon", "Tue", "Wed", "Thu", "Fri", "Sat", and "Sun". "Mon" through "Fri" are checked, while "Sat" and "Sun" are unchecked.
- Time Period:** An empty text input field with a green plus icon to its right.

At the bottom of the form, there are three buttons: "Cancel", "Save", and "Reset".

Table 5-23 Explanation of Time Parameters

Name	The name of the number profile
Date Period	Configure the starting date and ending date of a period  : Add a date period  : Delete a date period
Weekdate	Choose a weekdate
Time Period	Choose the starting time and ending time of a day

5.5.6 Manipulation

Number manipulation refers to the change of a called number or a caller number during calling process when the called number or the caller number matches the preset rules.

Click the **New** button, and you will see the following interface:

Figure 5-58 Create Manipulation Profile

Profile / Manipulation / New

Index: 1

Name: Manipulation 1

Caller:

Delete Prefix Count:

Delete Suffix Count:

Add Prefix:

Add Suffix:

Replace by:

Called:

Buttons: Cancel, Save, Reset

Table 5-24 Explanation of Manipulation Parameters

Name	The name of this manipulation profile
Delete Prefix Count	The number of digits that are deleted from the left of the caller number or callee number
Delete Suffix Count	The number of digits that are deleted from the right of the caller number or callee number
Add Prefix	The prefix added to the caller number or the callee number
Add Suffix	The suffix added to the caller number or the callee number
Replace by	The number which replace the caller number or the callee number
<input checked="" type="checkbox"/>	If the checkbox on the right of Caller is selected, it means the caller number will be manipulated; if the checkbox on the right of Called is selected, it means the called number will be manipulated.

Note: During number manipulation, deletion rules are carried out first, followed by adding rules. If 'Replace by' has been set, deletion rules and adding rules are invalid.

5.5.7 Dialplan

Dialplan is used for number dialing of calls through FXS and FXO ports. It supports Regular Expression (Regex) and DigitMap.

Figure 5-59 Add Dialplan

Profile / Dialplan / New

Index

Name

Format

Dialplan

Regex (Regular Expression) Syntax

^	Matches the starting position in a number string. For example, ^134 matches the numbers starting with 134
\$	Matches the ending position of a string. For example, 2\$ matches the numbers ending with 2.
	Separates alternate possibilities. For example, 2 3 4 means 2,3or 4.
[]	Matches a single character that is contained within the bracket. For example, [123] matches 1, 2, or 3. [0-9] matches any digit from "0" to "9".
[^]	Matches any one character except those enclosed in []. For example, [^9] matches any character except 9.
.	Matches any single character except the newline character. For example, 3.4 matches 314, 324, 334, 344.
?	Indicates there is zero or one of the preceding element. For example, colou?r matches both color and colour
*	Indicates there is zero or more of the preceding element. For example, ab*c matches ac, abc, abbc, abbbc, and so on.
+	Indicates there is one or more of the preceding element. For example, ab+c matches abc, abbc, abbbc, and so on, but not ac
\d	Mark any digit, equal to [0-9]

Examples of Regex Syntax:

^0755	Matches the phone numbers with starting digits of 0755.
-------	---

<code>^0755 ^8899 ^0110</code>	Matches the phone numbers with starting digits of 0755, 8899 or 0110.
<code>^[1][358][0-9]{9}\$</code>	Matches the phone numbers with the first digit as 1, the second digit as 3, 5 or 8, the left nine digits as any of 0 to 9.

DigitMap Syntax:

Supported Objects	Digit	0-9
	T	Timer
	DTMF	A digit, a timer, or one of the symbols of A, B, C, D, #, or *
Range	[]	One or more DTMF symbols enclosed in the [], but only one DTMF symbol can be selected
Range	()	One or more expressions enclosed the (), but only one can be selected
Separator		Separate expressions or DTMF symbols.
Subrange	-	Two digits separated by hyphen (-) which matches any digit between and including the two digits.
Wildcard	x	Matches any digit of 0 to 9
Modifiers	.	Matches 0 or more times of the preceding element
Modifiers	?	Matches 0 or 1 times of the preceding element

Examples of DigitMap Syntax





<code>(13 15 18)xxxxxxxx</code>	Matches the phone numbers with starting digits as 13, 15 or 18 and the left nine digits as any of 0 to 9
<code>[2-8]xxxxxx 13xxxxxxxx</code>	Matches the phone numbers starting with any digit of 2 to 8 and the left six digits as any of 0 to 9; or matches the phone numbers starting with 13 and the left nine digits as any of 0 to 9

5.6 Extension

5.6.1 SIP

On the **Extension** → **SIP** page, you can configure the SIP accounts registered in the UC200-2S2O by SIP clients (hereby UC200-2S2O is regarded as a SIP server).

Figure 5-60 Configure SIP Extension

Extension / SIP								
Index	Name	Extension	DID	Password Auth	Register Source	Profile	Status	
1	1000	1000		On	Any	2-< wan_default >	Enabled	 
2	1001	1001		On	Any	2-< wan_default >	Enabled	 



Extension / SIP / Edit	
Index	1
Name	<input type="text" value="1000"/>
Extension	<input type="text" value="1000"/>
Password	<input type="password" value="...."/> 
DID	<input type="text"/> 
Register Source	<input type="text" value="Any"/>
Call Waiting	<input type="text" value="Off"/>
Do Not Disturb	<input type="text" value="Off"/>
Call Forward Unconditional	<input type="text" value="Off"/>
Call Forward Unregister	<input type="text" value="Off"/>
Call Forward Busy	<input type="text" value="Off"/>
Call Forward No Reply	<input type="text" value="Off"/>
NAT	<input type="text" value="Off"/>
Call In Filter	<input type="text" value="Black List"/>
Call In Black List	<input type="text" value="< Add New ...>"/>
Call Out Filter	<input type="text" value="White List"/>
Call Out White List	<input type="text" value="< Add New ...>"/>
SIP Profile	<input type="text" value="2-< wan_default >"/>
Status	<input type="text" value="Enable"/>
<input type="button" value="Cancel"/> <input type="button" value="Save"/> <input type="button" value="Reset"/>	

Table 5-25 Explanation of Parameters for SIP Extension

Name	The name of this SIP extension
------	--------------------------------

Extension	The SIP account of the extension registered in UC200 by a SIP client
Password	The password of the SIP account registered in UC200 by a SIP client
DID	Direct Inward Dialing; if the called number is same with DID, the call will be directly forwarded to the extension, rather than choosing a route. You are allowed to set multiple DIDs.
Register Source	If 'Any' is chosen, all SIP clients are allowed to register the SIP account of this extension; if 'Specified' is chosen, only the SIP client with the specified IP address or network segment is allowed to register the SIP account of this extension. For example, 172.16.0.0/16 means the register source is 172.16
Call Waiting	If a calling party places a call to a called party which is otherwise engaged, and the called party has the call waiting feature enabled, the calling party will hear an IVR voice.
Do Not Disturb	If 'Do Not Disturb' feature is enabled, calls cannot reach the called party.
Call Forward Unconditional	If 'Call Forward Unconditional' feature is enabled, all incoming calls will be forwarded to the chosen SIP extension or SIP trunk
Call Forward Unregister	If 'Call Forward Unregister' feature is enabled, all incoming calls that are not registered will be forwarded to the chosen SIP extension or SIP trunk
Call Forward Busy	If 'Call Forward Busy' feature is enabled, new coming call will be forwarded when the corresponding local port is busy.
Call Forward No Reply	If 'Call Forward No Reply' feature is enabled, calls will be forwarded when nobody answer the calls during a specified period.
NAT	If NAT is enabled, the IP address of SIP extension in LAN will be turned into the outbound IP address of public network, thus making NAT traversal possible
Call In Filter	If 'Call In Filter' is enabled, incomings calls (caller numbers) need to be matched with the selected black list or white list.
Call Out Filter	If 'Call Out Filter' is enabled, outgoing calls (callee numbers) need to be matched with the selected black list or white list.
SIP Profile	The SIP profile that is selected for the extension
Status	If it is enabled, this SIP extension is registered to UC200-2S2O; Otherwise the SIP extension is not registered

5.6.2 FXS

On the **Extension** → **FXS** page, you can configure the parameters of the FXS extension.

Figure 5-61 Configure Parameters of FXS Extension

Extension / FXS / Edit

Extension	<input type="text" value="8000"/>
DID	<input type="text"/> +
Register to SIP Server	<input type="text" value="On"/>
Master Server	<input type="text" value="SIP Trunk / 95.22"/>
Slave Server	<input type="text" value="Not Config"/>
Username	<input type="text" value="1000"/>
Auth Username	<input type="text" value="1000"/>
Password	<input type="password" value="...."/> 👁
Specify Transport Protocol on Register URL	<input type="text" value="Off"/>
Expire Seconds	<input type="text" value="1800"/>
Retry Seconds	<input type="text" value="60"/>
Hot Line	<input type="text" value="Off"/>
Call Waiting	<input type="text" value="Off"/>
Do Not Disturb	<input type="text" value="Off"/>
Call Forward Unconditional	<input type="text" value="Off"/>
Call Forward Busy	<input type="text" value="Off"/>
Call Forward No Reply	<input type="text" value="Off"/>
Input Gain	<input type="text" value="0 dB"/>
Output Gain	<input type="text" value="0 dB"/>
Work Mode	<input type="text" value="Voice"/>
Call In Filter	<input type="text" value="Black List"/>
Call In Black List	<input type="text" value="< Add New ...>"/>
Call Out Filter	<input type="text" value="White List"/>
Call Out White List	<input type="text" value="< Add New ...>"/>
FXS Profile	<input type="text" value="1-< default >"/>
Status	<input type="text" value="Enable"/>

Table 5-26 Explanation of Parameters for FXS Extension

Extension	The extension account of FXS port, which is used to register
DID	Direct Inward Dialing; if the called number is same with DID, the call will be directly forwarded to the extension, rather than choosing a route.
Register to SIP Server	If it is enabled, the FXS extension account will be registered to the SIP trunk that has been set. Default is off.
Master Server	The address and port of the master SIP server; It is generally the IP address of a SIP trunk. Please make reference to Trunk → SIP section
Slave Server	The address and port of the slave SIP server
Username	The username of the FXS account, which will be used during registration
Auth Username	The auth username of this FXS account, which is used during register authentication
Password	The password of this FXS account, which is used during register authentication
Specify Transport Protocol on Register URL	Whether to specify transport protocol on register URL.
Expire Seconds	The validity period after the FXS account is registered successfully. When the time expires, the UC200 will send register request to the server. Default value is 1800s
Retry Seconds	When the FXS account fails to be registered, the interval to send register request; Default value is 60s
Hot line	If hotline is enabled, calls will directly go to the hotline number
Number	Hotline number
Call Waiting	If a calling party places a call to a called party which is otherwise engaged, and the called party has the call waiting feature enabled, the calling party will hear an IVR voice.
Do Not Disturb	If 'Do Not Disturb' feature is enabled, calls cannot reach the called party.
Call Forward Unconditional	If 'Call Forward Unconditional' feature is enabled, all coming calls will be forwarded to the selected extension or trunk.
Call Forward Busy	If 'Call Forward Busy' feature is enabled, new coming call will be forwarded when the corresponding local port is busy.

Call Forward No Reply	If 'Call Forward No Reply' feature is enabled, calls will be forwarded when nobody answer the calls during a specified period.
Input Gain	The receiving gain of the FXS port
Output Gain	The sending gain of the FXS port
Work Mode	The working mode of the FXS port, including Voice and POS
Call In Filter	If 'Call In Filter' is enabled, incomings calls (caller numbers) need to be matched with the selected black list or white list.
Call Out Filter	If 'Call Out Filter' is enabled, outgoing calls (callee numbers) need to be matched with the selected black list or white list.
FXS Profile	The FXS profile that is selected for this FXS extension
Status	If it is on, this FXS extension can be used, otherwise, the FXS extension is unavailable.

5.6.3 Ring Group

On the **Extension → Ring Group** page, you can group FXS extension and SIP extension(s) together and set strategy for choosing an extension to ring under the ring group. The ring group function is widely used in call centers.

Figure 5-62 Configure Ring Group

Extension / Ring Group / New

Index:

Name:

Members Select:

- ⊗
- ⊗
- ⊗ ⊕



Strategy:

Ring Group Number:

DID:

Ring Time(5s~200s):

Table 5-27 Explanation of Parameters for Ring Group

Name	The name of this ring group
Members Select	Select the FXS extension and an SIP extension or several SIP extensions;  : Add an extension to the ring group  : Delete an extension from the ring group
Strategy	The strategies for choosing which SIP extension to ring, including Sequence (Ascending), Sequence (Cyclic Ascending), Simultaneous and Random
Ring Group Number	The number of the ring group; it is generally the same with DID.
DID	Same with Ring Group Number; it is optional to fill in
Ring Time (5-60s)	The duration of ring when there is an incoming call. Range: 5s to 60s









Note: If ring group function has been set, the call forwarding function is unavailable.

5.7 Trunk

5.7.1 SIP

SIP trunk can realize the connection between UC200-2S2O and IPPBX or SIP servers.

Figure 5-63 Configure SIP Trunk

Trunk / SIP							
Index	Name	Realm	Transport	Heartbeat	Register	SIP Profile	Status
1	SIP Trunk1	172.21.80.100:5566	UDP	Off	Off	1-< lan_default >	Enabled   
2	0.157	172.18.0.157:5060	UDP	Off	Off	2-< wan_default >	Enabled   
3	0.123	172.18.0.123:5080	UDP	Off	Off	2-< wan_default >	Enabled   

[New](#)

Trunk / SIP / Edit

Index	1
Name	<input type="text" value="Telecom1"/>
Address	<input type="text" value="172.16.111.65"/>
Port	<input type="text" value="5080"/>
Outbound Proxy	<input type="text"/>
Port	<input type="text"/>
Transport	<input type="text" value="UDP"/>
Register	<input type="text" value="Off"/>
Heartbeat	<input type="text" value="Off"/>
SIP Profile	<input type="text" value="2-< wan_default >"/>
Status	<input type="text" value="Enable"/>

Table 5-28 Explanation of Parameters for SIP Trunk

Name	The name of the SIP trunk
Address	The IP address or domain name of the peer SIP devices or servers
Port	The SIP listening port of the peer SIP devices or servers; 5060 is the default port
Outbound Proxy	If outbound proxy is used, enter the IP address or domain name of the proxy server
Port	If outbound proxy is used, enter the listening port of the proxy server
Transport	Transport protocol: TCP or UDP
Register	If it is on, the SIP trunk will send register request to the peer device
Username	The username of this SIP trunk, it is generally a phone number
Auth Username	The username used for register authentication by this SIP trunk
Password	The password used for register authentication by this SIP trunk
From Header	Choose the registered username or the true caller ID for the 'from

Username	header' of the invite message when a call goes out.
Expire Seconds	The validity period after the SIP trunk is registered successfully. When the time expires, the SIP trunk will send register request to the server. Default value is 1800s
Retry Seconds	When the SIP trunk fails to be registered, the interval to send register request; Default value is 60s
Heartbeat	If heartbeat in on, heartbeat (options) messages will be sent to examine the connection with servers; The default value is 'Off'
Heartbeat Period	The interval of sending heartbeat (options) messages
SIP Profile	he SIP profile of the SIP Trunk; make reference to Profile → SIP section
Status	If it is enabled, it means the SIP Trunk can be used; otherwise, the SIP trunk is unavailable

Note:

If UC200-2S2O is regarded as a terminal and intends to register to a server, you need to configure a SIP trunk connecting UC200-2S2O and the server, and then enable register for the SIP trunk.

If the FXS port of UC200-2S2O intends to register to a server, you need to configure a SIP trunk connecting UC200-2S2O and the server, then enable register for the FXS port and designate the SIP trunk to it.

5.7.2 FXO

FXO trunk interconnects the PSTN with UC200-2S2O. Calls from the PSTN can come into the UC200-2S2O gateway and calls can go out from the gateway to search telephone numbers under the PSTN.

Different from the FXO ports of other gateways, the FXO port of UC200-2S2O only allows one-time dialing, which means called numbers needs to be dialed directly for calls that go out from the FXO port.

Figure 5-64 Configure FXO Trunk

Trunk / FXO

FXO Automatch Impedance Busytone Learning

Trunk / FXO / Edit

Port 1

Extension

Autodial Number

Register to SIP Server

Display Name / Username Format

Display Name / Username Format when CID unavailable

Input Gain

Output Gain

Impedance

FXO Profile

Status

Table 5-29 Explanation of Parameters for FXO Trunk

Port	The serial number of the FXO port
Extension	The extension account of the FXO port, which is used to register
Autodial Number	The autodial number of the FXO port when there are incoming calls
Register to SIP Server	If it is enabled, the FXO trunk will be registered to the SIP trunk that has been set. Default is off.
Master Server	The address and port of the master SIP server; It is generally the IP address of a SIP trunk. Please make reference to Trunk → SIP section
Slave Server	The address and port of the slave SIP server
Username	The user name of the FXO trunk, which will be used during registration
Auth Username	The username of this FXO trunk, which is used during register authentication

Password	The password of this FXO trunk, which is used during register authentication
From Header Username	Choose the registered username or the true caller ID for the 'from header' of the invite message when a call goes out.
Specify Transport Protocol on Register URL	Whether to specify transport protocol on register URL.
Expire Seconds	The validity period after the FXO trunk is registered successfully. When the time expires, the FXO trunk will send register request to the server. Default value is 1800s
Retry Seconds	When the FXO trunk fails to be registered, the interval to send register request; Default value is 60s
Display Name/Username Format	The format to display caller information, including: Caller ID/Caller ID Display Name/ Caller ID Extension/ Caller ID Caller ID/ Extension Anonymous
Display Name / Username Format when CID unavailable	Set the caller's caller id format when the main number is not detected
Input Gain	The receiving gain of the FXO port
Output Gain	The sending gain of the FXO port
Impedance	The impedance (SLIC) matched with phones
FXO Profile	The FXO profile that is selected for this FXO extension
Status	If it is on, this FXO trunk can be used, otherwise, the FXO trunk is unavailable.

FXO Automatch Impedance:

Choose a FXO port and then click the **Start** button, the UC200-2S2O gateway will automatically detect the most-matched impedance.

Figure 5-65 FXO Automatch Impedance

Trunk / FXO

FXO Automatch Impedance Busytone Learning

FXO Port 1

Current Impedance 600 Ohm

Current Transhybrid Balancing Param 0

DTMF 1234567890123456789 **Start**

Automatch Optimum Impedance

Automatch Optimum Transhybrid Balancing Param

Cancel **Save**

Busytone Learning:

Choose a FXO port, enter destination number and then click the **Start** button, the UC200-2S2O gateway will automatically detect the busy tone.

Trunk / FXO

FXO Automatch Impedance **Busytone Learning**

FXO Port 1

Current Candence 0,0,0,0,0,0,0,0

Destination Number 1234567890# **Start**

Original Candence

Automatch Optimum Candence

Cancel **Save**

5.8 Call Control

This section is to configure routes or route groups for incoming and outgoing calls through UC200-2S2O, as well as IVR, SMS and so on.

5.8.1 Setting

Figure 5-66 Basic Setting of Call Control

Call Control / Setting	
Voice	
Disconnect call when no RTP packet	<input type="checkbox"/>
Packet Loss Concealment(PLC)	<input type="checkbox"/>
Echo Path Change Detection(EPCD)	<input checked="" type="checkbox"/>
Non-Linear Processor(NLP)	Low
Echo Gain	-4dB
Echo Canceller Tail Length(ms)	128
DTMF Min Detect Interval(ms)	0
RTP Start Port	16000
RTP End Port	16200
Tone	
Waiting Music	Default Tone
Route	
Local extension call	<input checked="" type="checkbox"/>
FXO extension dial out	<input checked="" type="checkbox"/>
FAX	
Send Mode	T.30
Tone Detection by Local	<input type="checkbox"/>
SDP Param	

Table 5-30 Explanation of Parameters for Call Control

Disconnect call when no RTP packet	If it is enabled, and no RTP packets are received within the preset time, calls will be disconnected
Packet Loss Concealment (PLC)	Whether to enable the 'Packet Loss Concealment' function
Echo Path Change Detection (EPCD)	If this function is enabled, it will be detected when echo path has a change
Non-Linear Processor (NLP)	You can choose Off, Low and Normal
Echo Gain	Default echo gain: -4dB
Echo Canceller Tail Length (ms)	Default value: 64ms
DTMF Min Detect Interval (ms)	The minimum time for DTMF detection
RTP Start Port	The start port of RTP packets
RTP End Port	The end port of RTP packets
Tone: Waiting Music	Default tone
Local extension call	If it is enabled, calls between local extensions do not need routes.
Fax Mode	T38 or T30 (Pass-through)
Tone Detection by Local	If it is enabled, UC200-2S20 will detect fax tones automatically during a call and the call will be switched into fax mode after a fax tone is detected.
SDP Param 'a=X-fax'	Attribute parameter 'a=X-fax' is carried in SDP
SDP Param 'a=fax'	Attribute parameter 'a=fax' is carried in SDP
SDP Param 'a=X-modem'	Attribute parameter 'a=X-modem' is carried in SDP

5.8.2 Route Group

On the **Call Control →Route Group** page, you can group SIP trunks, SIP extensions, FXS extension and FXO trunk together according to your needs and set strategy for choosing which trunk or extension as the destination route under a route group.

Figure 5-67 Create Route Group

The screenshot shows a web interface for creating a new route group. The title is 'Call Control / Route Group / New'. The form contains the following fields:

- Index:** A dropdown menu with the value '1' selected.
- Name:** A text input field containing 'Route Group 1'.
- Members Select:** A list of four dropdown menus:
 - SIP Trunk / Telecom1 (with a red 'x' icon)
 - FXS Extension (with a red 'x' icon)
 - SIP Extension / SIP Extensio (with a red 'x' icon)
 - FXO Trunk (with a red 'x' icon and a green '+' icon)
- Strategy:** A dropdown menu with the value 'Sequence(Ascending)' selected.

At the bottom of the form, there are three buttons: 'Cancel', 'Save', and 'Reset'.

Table 5-31 Explanation of Parameters for Route Group

Name	The name of the route group
Members Select	Select FXS extension, SIP extension, SIP trunk or FXO trunk
Strategy	The strategies for choosing which route under the route group as the destination route, including Sequence (Ascending), Sequence (Cyclic Ascending), Simultaneous and Random

5.8.3 Route

On the **Call Control** → **Route** page, you can configure routes for incoming calls and outgoing calls.

Figure 5-68 Create a Route

Call Control / Route / Edit

Priority

Name

Condition

Source

Number Profile

Caller Number Prefix

Called Number Prefix

Time Profile

Action

Manipulation

Destination

Recording Profile

Failover Action

Table 5-32 Explanation of Route Parameters

Priority	The priority for choosing the route; the higher value, the lower priority
Name	The name of the route
Condition	The condition under which the route will be used
Source	The source of the call; it can be the FXS extension, SIP extension, FXO trunk , SIP trunk, a customized source or any
Number Profile	The profile of the caller number and the called number; please make reference to the Profile → Number section. The default value is 'Off' Note: it cannot be simultaneously used with the following parameters of 'caller number prefix' and 'called number prefix'
Caller Number Prefix	The prefix of caller number; it supports regular expression
Called Number Prefix	The prefix of called number; it supports regular expression

Time Profile	The time profile during which the route can be used; when a call is initiated at a time falling into the time range of this time profile, the call will choose the route. make reference to the Profile → Time section
Action	Include manipulating number and sending call to destination
Manipulation	If it is on, the caller number or called number of the route will be manipulated; make reference to the Profile → Manipulation section
Destination	The destination of the route
Failover Action	The processing when a call through this route fails

5.8.4 Feature Code

UC200-2S20 provides convenient telephone functions. Connect a telephone to the FXS port and dial a specific feature code, and you can query corresponding information.

The following is the corresponding function of each feature code:

Figure 5-69 Feature Code

Call Control / Feature Code

Feature Code Service

Index	Feature	Key	Description	Status	
1	Inquiry LAN IP	*158	Inquiry LAN IP	Ena...	
2	Inquiry WAN IP	*159	Inquiry WAN IP	Ena...	
3	Inquiry Phone Number	*114	Inquiry Phone Number	Ena...	
4	Network Work Mode	*157*	Dail *157*0 to set route mode.Dail *157*1 to set ...	Ena...	
5	IP Address Config Mode	*150*	*150*1#-Static, *150*2#-DHCP	Ena...	
6	Configure IP Address	*152*	Set IPv4 Address 192.168.1.10 by dial *152*192*...	Ena...	
7	Configure Gateway	*156*	Set IPv4 Gateway 192.168.1.1 by dial *156*192*...	Ena...	
8	Configure Subnet Mask	*153*	Set IPv4 Netmask 255.255.0.0 by dial *153*255*...	Ena...	
9	Restart Device	*111	Restart Device	Ena...	
10	Call Waiting Activate	*51	Enable Call Waiting service	Ena...	
11	Call Waiting Deactivate	*50	Disable Call Waiting service	Ena...	
12	Blind Transfer	*1	Example:*18000#,you can blind transfer to the ex...	Ena...	
13	Attended Transfer	*2	Example:*28000#,you can attended transfer to th...	Ena...	
14	Call Forwarding Unconditio...	*72*	Enable Call Forwarding Uncondition service.Exa...	Ena...	
15	Call Forwarding Unconditio...	*73	Disable Call Forwarding Uncondition service	Ena...	
16	Call Forwarding Busy Activate	*90*	Enable Call Forwarding Busy service.Example:*9...	Ena...	
17	Call Forwarding Busy Deac...	*91	Disable Call Forwarding Busy service	Ena...	
18	Call Forwarding No Reply ...	*92*	Enable Call Forwarding No Reply service.Examp...	Ena...	
19	Call Forwarding No Reply ...	*93	Disable Call Forwarding No Reply service	Ena...	
20	DND Activate	*78	Enable Do Not Disturb service	Ena...	
21	DND Deactivate	*79	Disable Do Not Disturb service	Ena...	
22	Group Pickup	**	Pick up the ringing extension which in the same r...	Ena...	
23	WAN Access Control	*160*	*160*1# - Allow HTTP WAN access, *160*0# - De...	Ena...	
24	Voicemail Service	*170*	*170*1# - Leave messages, *170*2# - Play mess...	Ena...	
25	Callback Service	*163	Callback the last received call	Ena...	
26	Recording Service	*3	Start or stop recording when manual recording	Ena...	

Note: All feature codes are enabled by default.

5.8.5 IVR

On the **Call Control** → **IVR** page, you can carry out specific configurations for the IVR which has been uploaded from the **System** → **Voice** page.

Figure 5-70 IVR Setting

Callcontrol / IVR / New

Index	1
Name	
Menu Tone	Off
Repeat Loops	3
Select Invalid Times	3
Select Invalid Tone	Off
Destination Invalid Times	3
Destination Invalid Tone	Off
Timeout	10
Timeout Tone	Off
Exit Tone	Off
Status	Enable

Menu

DTMF	Tone	Destination	
0	Off	Extension	SIP Extension / 1000

Cancel Save Reset

Table 5-33 Explanation of IVR Parameters

Name	The name of the IVR
Menu Tone	Choose a tone as the menu tone. It is generally the default tone
Repeat Loops	If it is set as '3', the call will be hanged up after the IVR has been repeated for three times
Select Invalid Times	The times of prompting that the caller has dialed an invalid DTMF digit. When this value is reached , the call will be hanged up
Select Invalid Tone	Select 'Off' or a tone which prompts that the caller has dialed an invalid DTMF digit
Destination Invalid Times	The times of prompting that the destination cannot be reached. When this value is reached , the call will be hanged up
Destination Invalid Tone	Select 'Off' or a tone which prompts that the destination cannot be reached
Timeout	If it is set as '10', it means if no DTMF tone is received during 10 seconds, the IVR will be played repeatedly or the call will be hanged up. The default value is 10 seconds.

Timeout tone	Select 'Off' or a tone which prompts the call has timed out.
Exit Tone	Select 'Off' or a tone which prompts to exit IVR
Status	If it is disabled, the IVR cannot be seen in the destination of route.
Menu	<p>DTMF: It is generally 0-9 quick-dial numbers to forward the call to the set destination.</p> <p>Destination: the destination of the IVR; it can be an extension or a trunk.</p> <p>For example, if DTMF is configured as 1,2,3 and others, and the telephone key that is pressed is not 1, 2 or 3, the IVR will choose the destination of 'others'.</p> <p>When the playing of the IVR times out, and user does not press any telephone key, the IVR will choose the destination of 'timeout'.</p> <p>When the destination is a trunk, user does not need to pre-configure the called number, and the system will prompt the user to dial the called number.</p>

5.8.6 SMS Route

UC200-2S2O allows SMS to be sent between SIP clients. On the **Call Control** → **SMS Route** page, you can establish route for these SMS.

For example, you can download a softphone on a PC which is connected to UC200-2S2O, and type the content of the SMS through the softphone. Then configure a SMS route on the **Call Control** → **SMS Route** page. The source of the SMS route is the number of the softphone.

Figure 5-71 Create SMS Route

Call Control / SMS Route / New

Priority

Name

From

Source

Content Has the Words

To

Action

Destination

Add Prefix in Content

Add Suffix in Content

Table 5-34 Explanation of SMS Route Parameters

Priority	The priority of the SMS route; the higher value, the lower priority
Name	The name of the SMS route
Source	The source of the SMS route. It can be a trunk, an extension or a softphone
Content Has the Words	the key words of the SMS content
Action	action can be 'forward' or 'reply' for the SMS
Destination	The destination of the SMS route. It can be a trunk or an extension.
Add Prefix in Content	The prefix of the SMS content. It is generally 'none', which means there is no prefix to be matched.
Add Suffix in Content	The suffix of the SMS content. It is generally 'none', which means there is no suffix to be matched.

5.8.7 Diagnostics

In case that call cannot be connected or voice has quality problem, you can enter into the **Call Control →Diagnostics** page to collect fault-related information and then send it to technical support to locate faults.

Operation Procedures:

1. Select the module that need to be traced. For example, if a call from SIP to FXS has voice problem, you can select SIP message, FXS/FXO and Voice, and then click the **Start** button.
2. Give a call, and come back to the **Call Control →Diagnostics** page after the call ends. Then click **Stop** and download the tracing file.
3. In order to locate faults more quickly, you sometimes need to enter into the **System →Service Log** page, click **Export**, and then send this exported file and the tracing file to technical support,

Figure 5-74 Call Tracing for Diagnostics

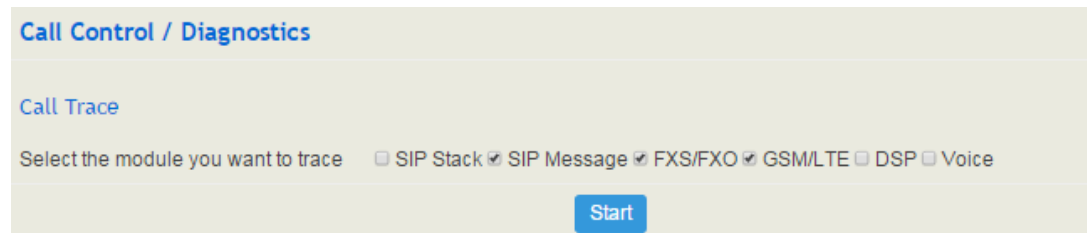

The screenshot shows the 'Call Control / Diagnostics' page. Under the 'Call Trace' heading, there is a label 'Select the module you want to trace' followed by a row of checkboxes: 'SIP Stack' (unchecked), 'SIP Message' (checked), 'FXS/FXO' (checked), 'GSM/LTE' (checked), 'DSP' (unchecked), and 'Voice' (unchecked). A blue 'Start' button is positioned below the checkboxes.

6 Glossary

Glossary	Description
ARP	Address Resolution Protocol
CID	<i>Caller Identity</i>
DNS	Domain Name System
DDNS	Dynamic Domain Name Service
DHCP	Dynamic Host Configuration Protocol
DMZ	Demilitarized Zone
DND	Do NOT Disturb
DTMF	DTMF: Dual Tone Multi Frequency
FTP	File Transfer Protocol
HTTP	Hypertext Transfer Protocol
LAN	Local Area Network
L2TP	Layer 2 Tunneling Protocol
PPTP	Point-to-Point Tunneling Protocol
MAC Address	Media Access Control Address
NAT	Network Address Translation
Ping	Packet Internet Grope
SIP	Session Initiation Protocol
TCP	Transmission Control Protocol
UDP	User Datagram Protocol
RTP	Real Time Protocol
PPPOE	Point-to-point Protocol over Ethernet
QoS	Quality of Service
UPnP	Universal Plug and Play
VLAN	Virtual Local Area Network

Glossary	Description
NTP	Network Time Protocol
STUN	Simple Traversal of UDP over NAT
PSTN	Public Switched Telephone Network
WLAN	Wireless Local Area Network